

Cowboy Mounted Shooting[®] Association Courses of Fire



Rangemaster Guide
2007

Cowboy Mounted Shooting® Association

Courses of Fire

The “course of fire” or pattern of riding is commonly referred to as a “stage” and should be designed for maximum enjoyment of competitors and spectators, while testing horsemanship and shooting skills. The safety of riders, spectators and horses is a principle concern.

The primary purpose of a stage is to provide a scoring grid that is fair for all contestants. A standard CMSA stage is to have ten targets. A contestant is to shoot the course of fire with two single action revolvers with five CMSA approved cartridges in each revolver. Revolvers are used one at a time. With the first revolver, a contestant shoots a random course of fire (the first half of the stage). This random course can be set in any safe manner. Upon completing the random course, the contestant holsters the now empty revolver and draws the second revolver and rides to shoot the second half of the stage (called the “Rundown”). The Rundown is standardized in all CMSA World Qualifying Matches. The Rundown is to have five targets to be completed in a fast, forward motion. The final five targets must be set in such a way that horse and rider are challenged to shoot the targets at a maximum rate of speed, according to their ability. It is specifically not the intention of the CMSA rules to penalize a fast horse and rider. After completing the stage, the contestant must immediately report to the armorer and unload both revolvers.

By varying the height of any target on any stage, one can create an entirely new course of fire.

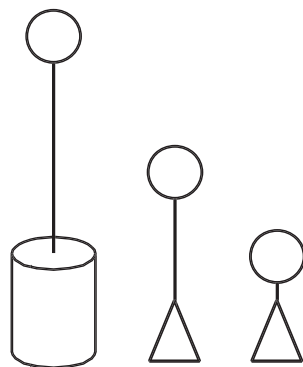

- **TTR 2-Target Rule** : If two targets are burst by gun fire, of same or different color, it will not be a miss and poles do NOT have to be shot. The extra round may be used to pick off a missed target.
- **Gate Rule:** targets do NOT have to be shot going through a gate. Rider must pass through the gate from either side. Horse's entire body must pass through gate - tails do not count.
- Targets should be a minimum distance of 12' from any barrel.
- If a target must be set on top of a barrel, it may be shot going in or coming out of the barrel, (this includes the Rundown barrel).
- **Rounding a Barrel:** Does not mean crossing your path or a 360° turn.
- **Full Barrel Turn:** Means crossing your path
- A rider may go back and round a barrel or pick up a gate to avoid a penalty.
- Standard spacing for a Rundown target is 36 feet.
- A standard Gate is 15 feet.
- Rundown in a straight line may be shot from either side and may be gone in between.
- Targets may be shot in any order, from either side, unless specifically noted.
- An ideal arena is 300 feet by 100 feet. Distance between the targets and barrels may be shortened to accommodate a smaller arena.
- It is each club's responsibility to insure arena safety. If, for any reason, a rider is concerned about the safety of an arena, they should withdraw from competition. Rider enter at their own risk.

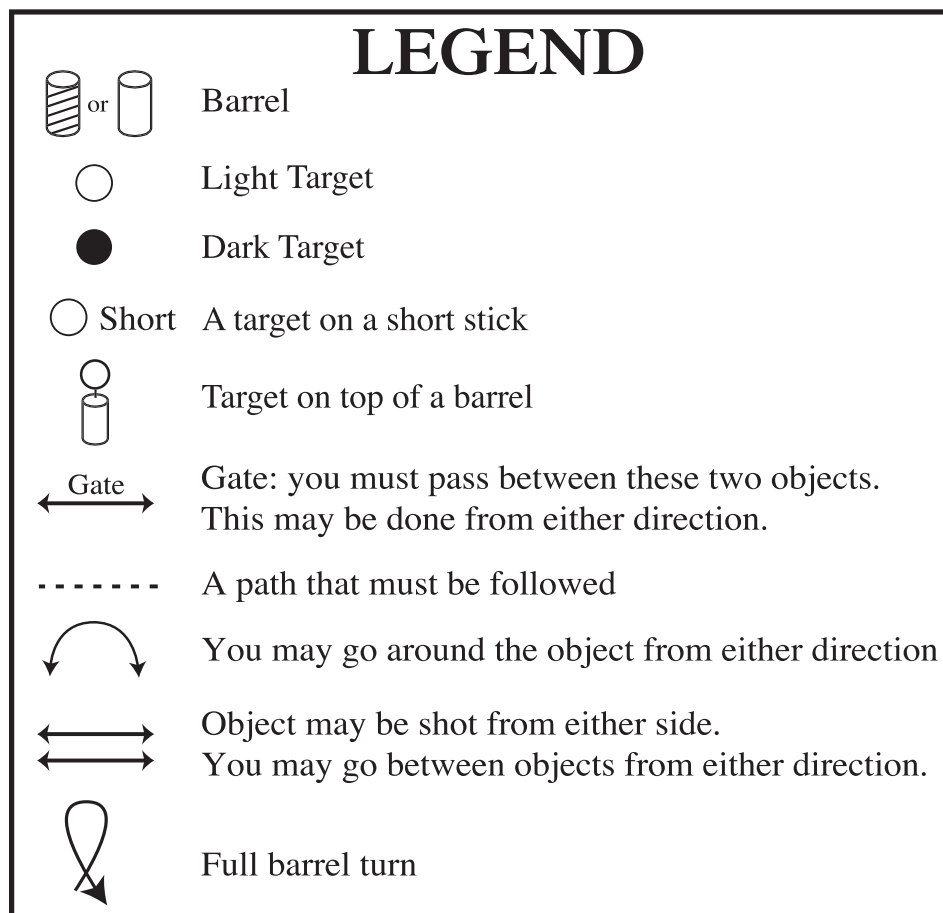

**Only Courses in the CMSA Coursebook may be used at WPQ Matches.
Failure to follow the course of fire means failure to follow the directions in the Coursebook.**

Instructions

- A. Shoot the farthest light targets first
- B. Shoot all the light targets first, before rounding the barrel
- C. Shoot 5 of one color, round the barrel, shoot 5 of the other color
- D. Stay on the outside of all of the light targets
- E. Pole Bend light targets
- F. Shoot 5, round the barrel, round the barrel, shoot 5
- G. Shoot light target last, shoot dark target last
- H. Shoot the entire Random course first, then round the Rundown barrel
- I. Shoot all the light targets first. Then shoot the dark targets. You must round the barrel

Procedurals

1. Failure to shoot the targets in the proper order
2. Failure to shoot all of the correct targets before rounding the barrel
3. Failure to round a barrel
4. Failure to go through a gate
5. Failure to follow the prescribed pattern

Notes

- When in doubt, favor the rider
- There is only ONE Procedure per stage
- If a rider corrects his/her mistake, there is no procedure.

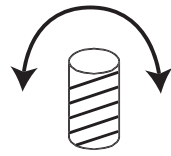

12'



TTR
Short

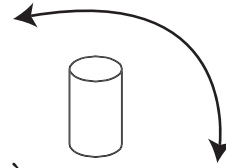

12'



Targets in gate do not
have to be shot going
through the gate.
Rider may enter gate
from either side.

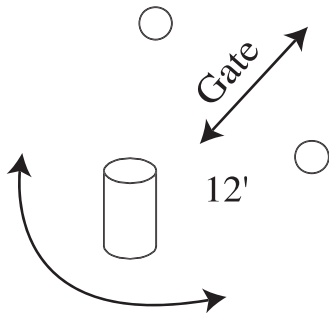

Start/Finish

#2

A. Shoot the farthest light targets first

H. Shoot the entire Random course first, then round the Rundown barrel

Procedurals: 1, 3, 4

Targets may be shot from either side or rider may go between poles.

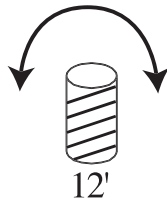
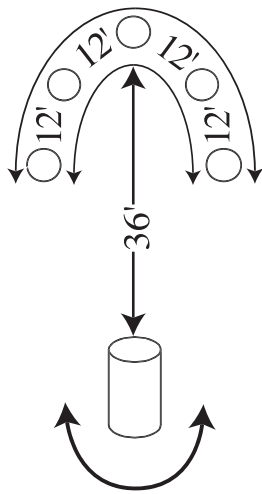

Start/Finish

#3

B. Shoot all the light targets first, before rounding the barrel

Procedurals: 2, 3

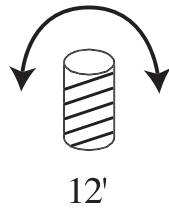

12'

Target may be shot from either side or rider may go between poles

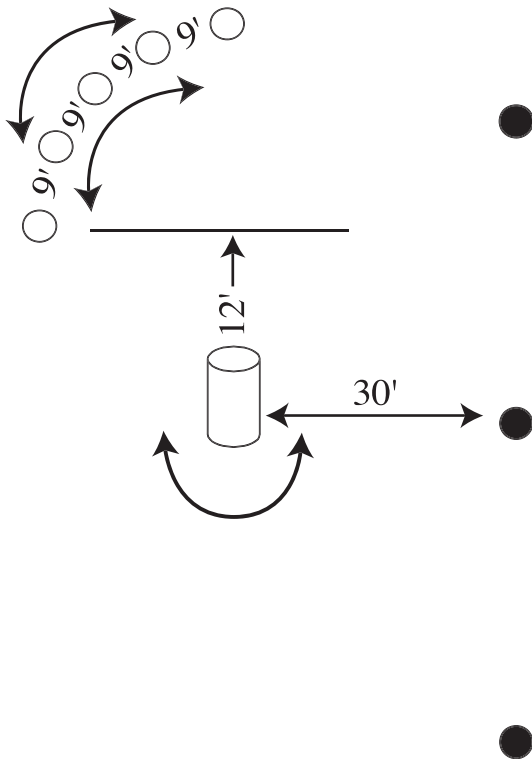

Start/Finish

#4

B. Shoot all the light targets first, before rounding the barrel

Procedurals: 2, 3

Target may be shot from either side or rider may go between poles.

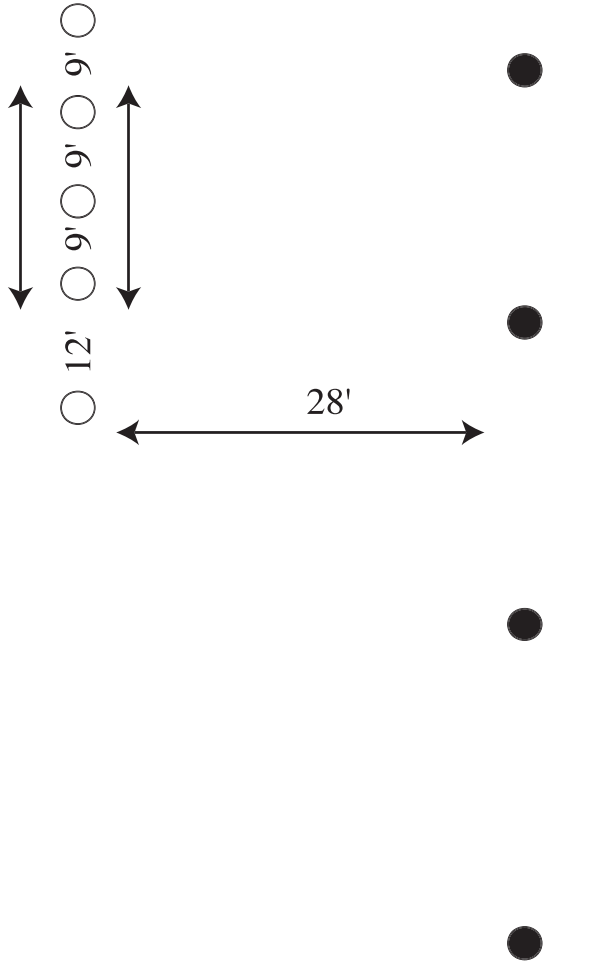

Start/Finish

#5

B. Shoot all the light targets first, before rounding the barrel

Procedurals: 2, 3

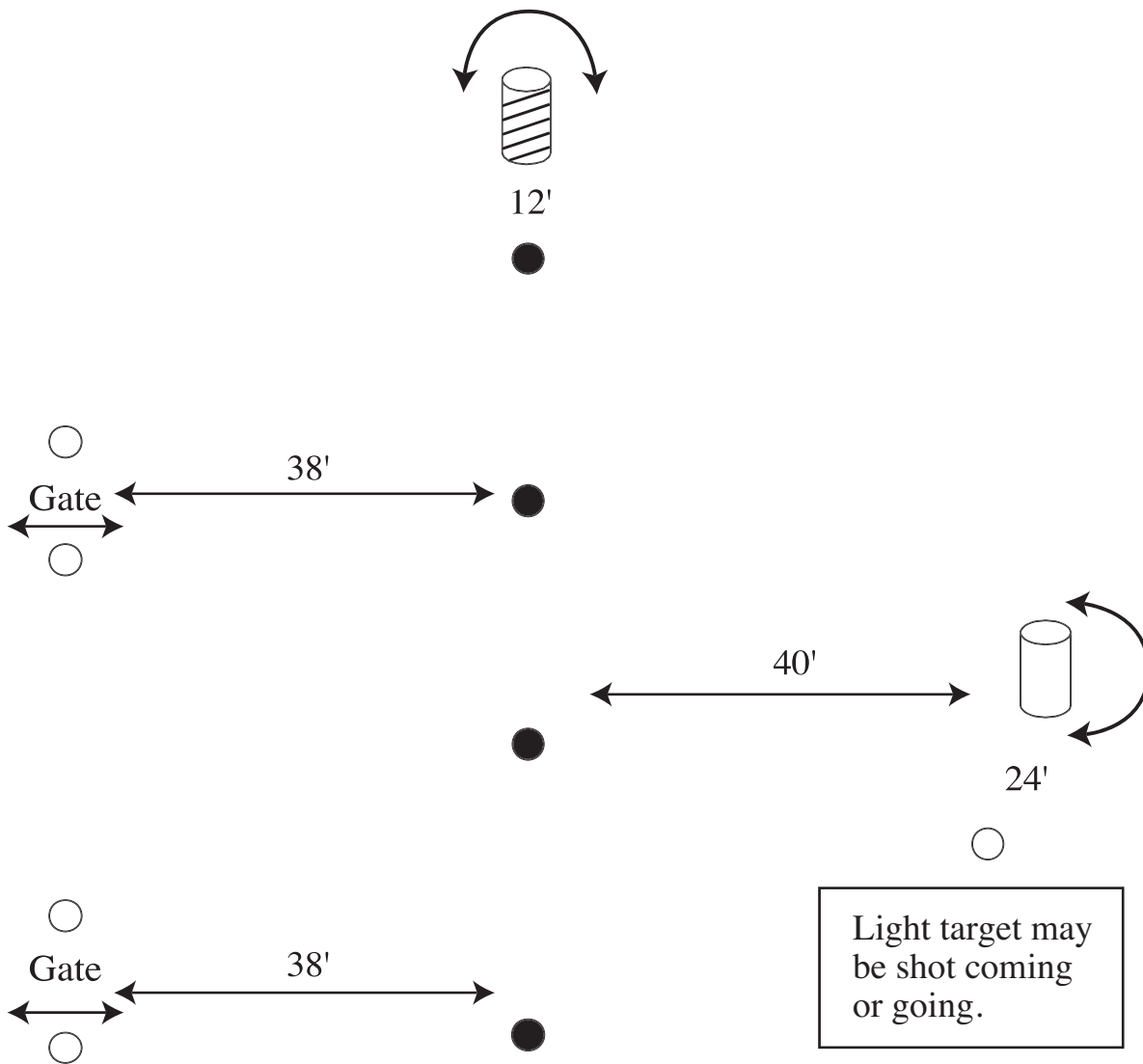

Target does not have to be shot while going through gate. Rider must pass through gate. Horse's total body must pass through gate.

Light target may be shot coming or going.

Start/Finish

#6

H. Shoot the entire Random course first, then round the Rundown barrel
 Procedurals: 2, 3, 4

Gate may be entered from either side, targets may be shot before, during or after gate is entered. Horse's body must pass completely through gate.

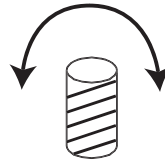

12'

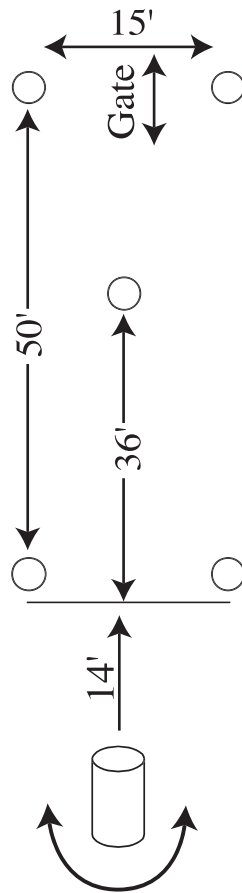

Start/Finish

#7

B. Shoot all the light targets first, before rounding the barrel

Procedurals: 2, 3, 4

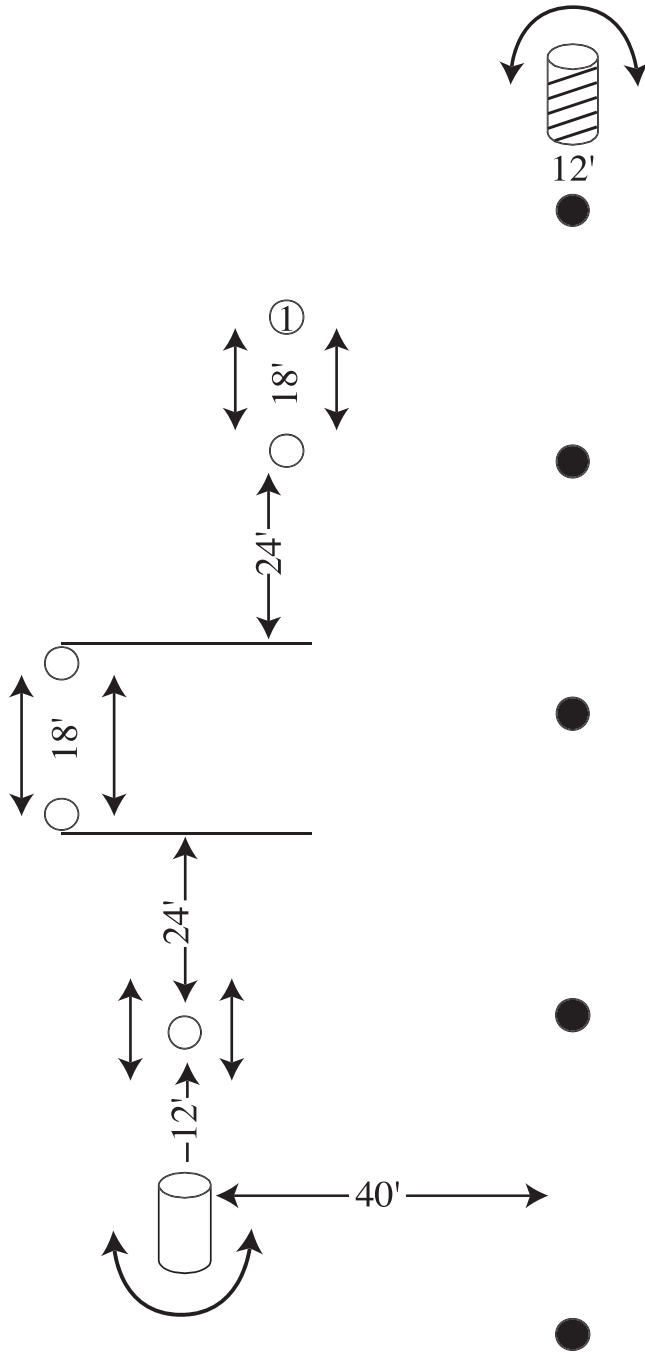

Start/Finish #8

- A. Shoot the farthest light targets first
 - B. Shoot all the light targets first, before rounding the barrel
- Procedurals: 1, 2, 3,

○ 20' ○ 20' ○ 20' ○ 20' ○



12'

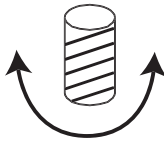

Start/Finish

#9

B. Shoot all the light targets first, before rounding the barrel

Procedurals: 2, 3

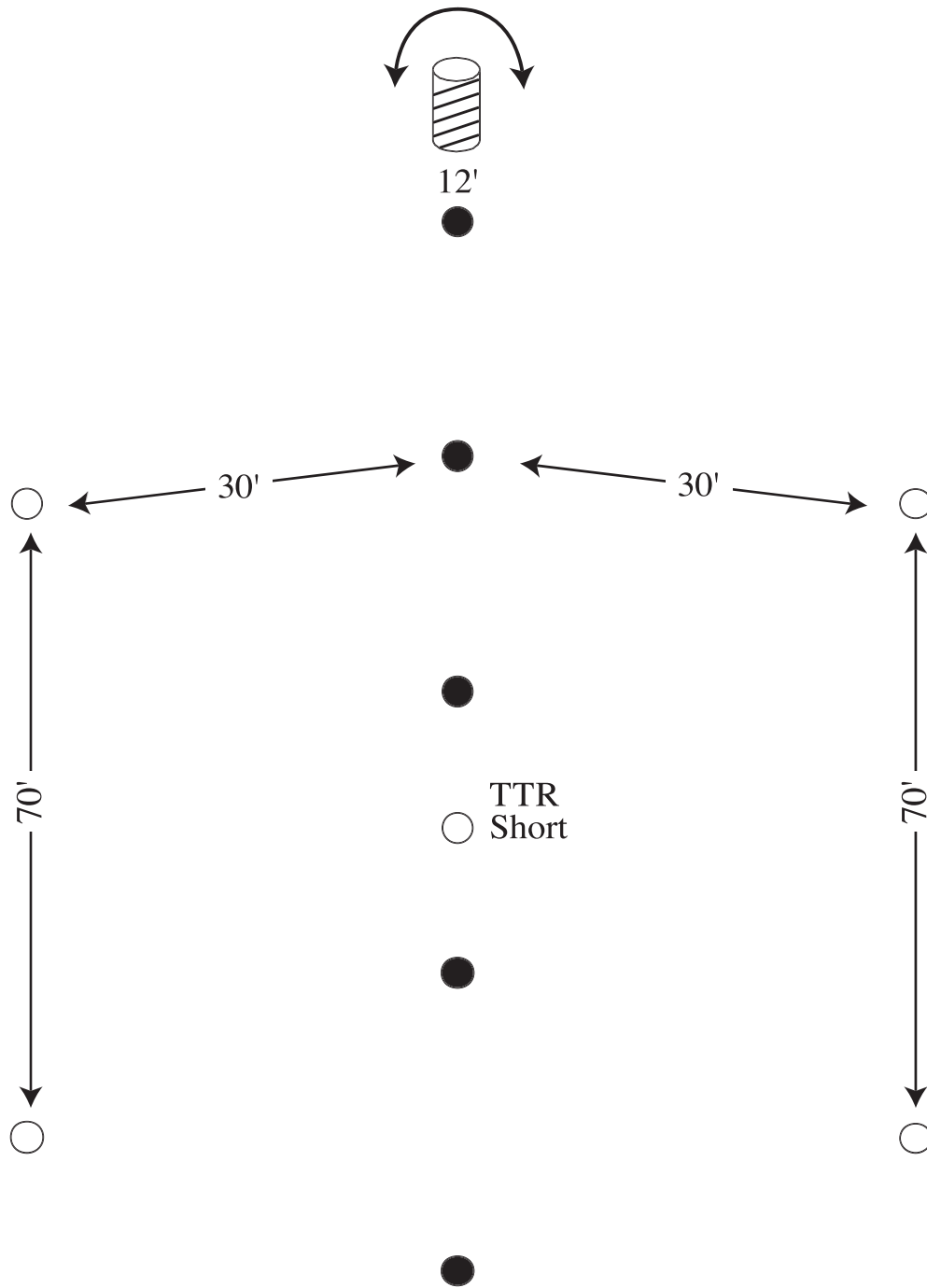

Start/Finish

 #10

B. Shoot all the light targets first, before rounding the barrel
 Procedurals: 2, 3

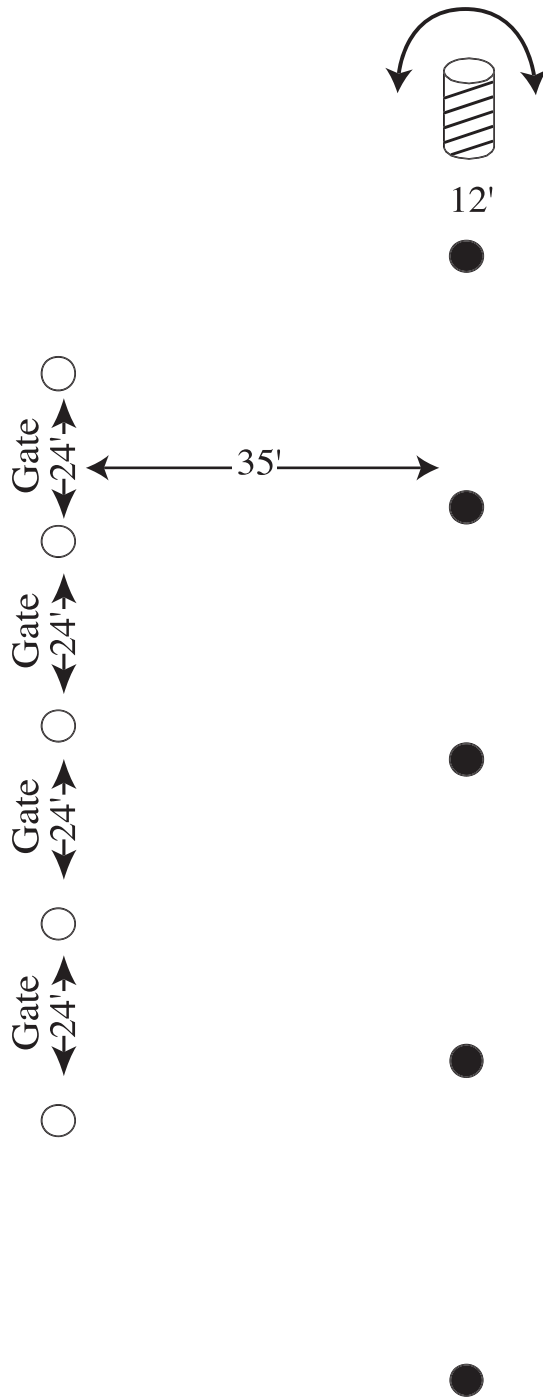

Begin Here

B. Shoot all the light targets first, before rounding the barrel
 Procedurals: 2, 3, 4

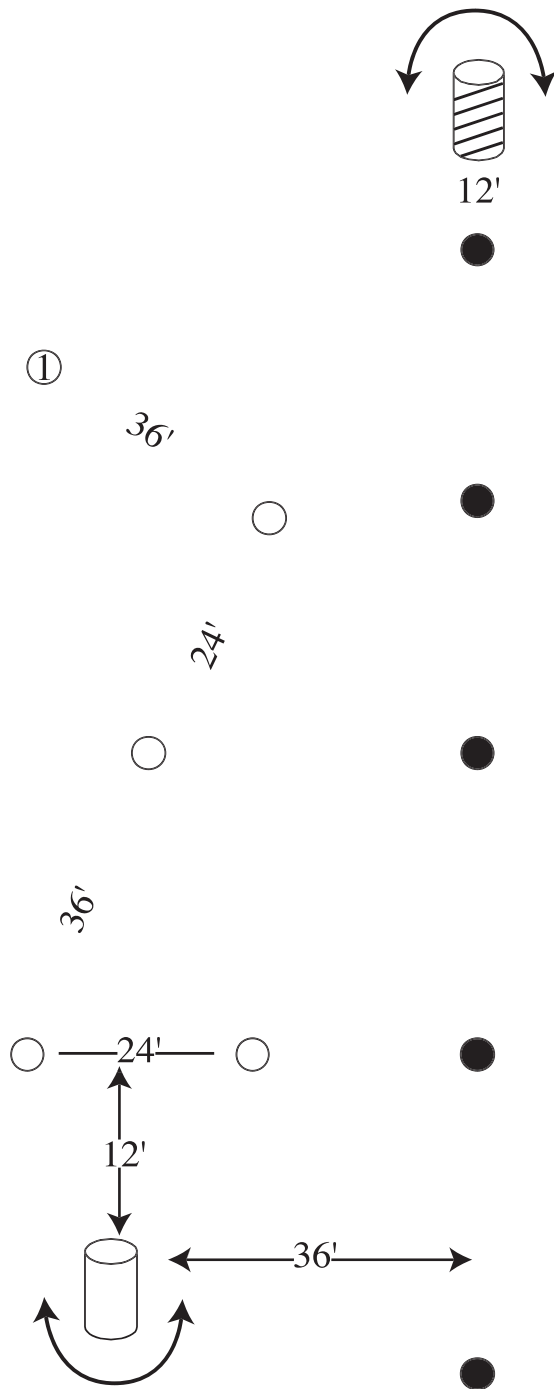

Start/Finish #13

- A. Shoot the farthest light targets first
 - B. Shoot all the light targets first, before rounding the barrel
- Procedurals: 1, 2, 3

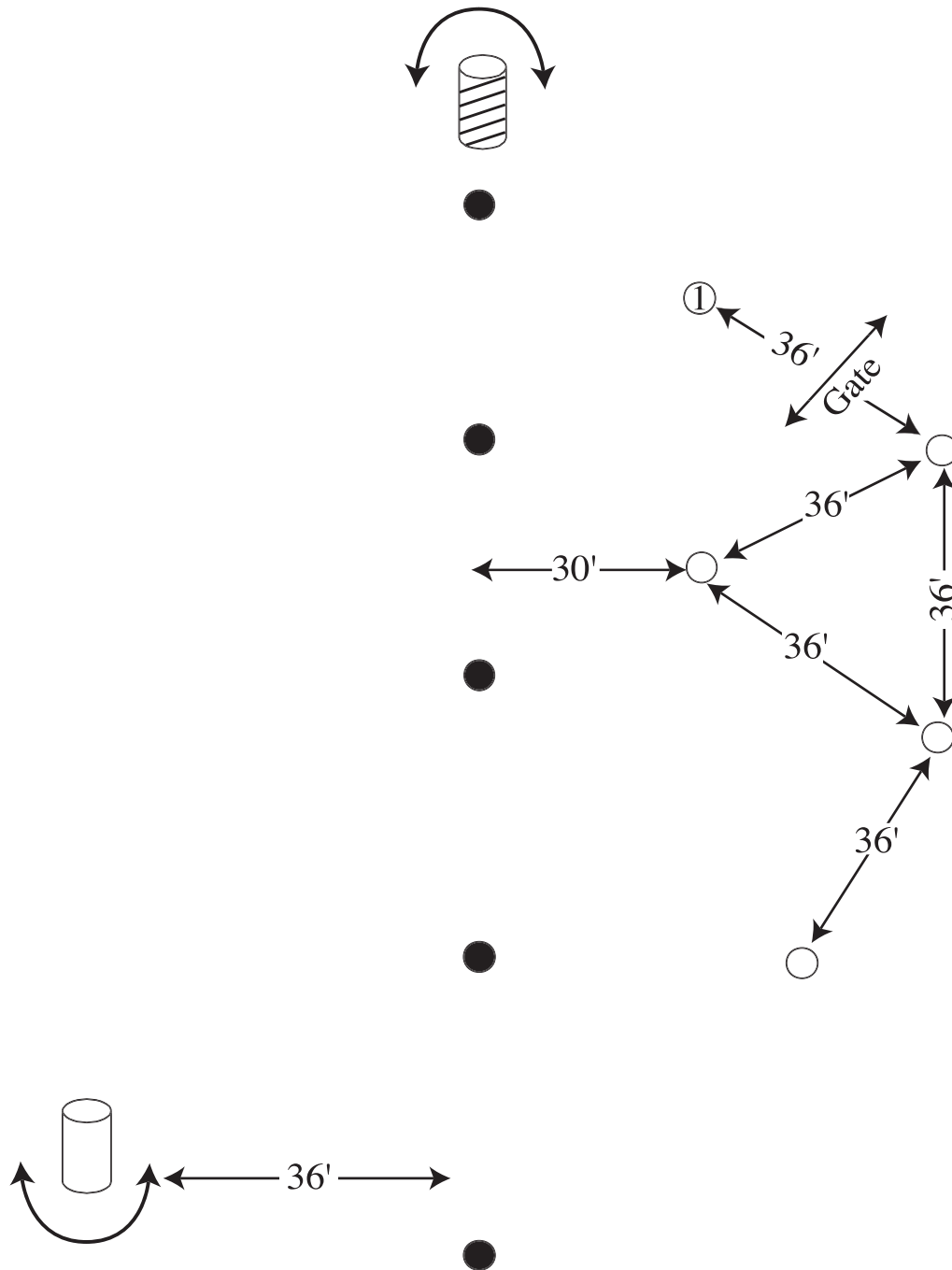

Start/Finish

#14

- A. Shoot the farthest light targets first
 - B. Shoot all the light targets first, before rounding the barrel
- Procedurals: 1, 2, 3, 4

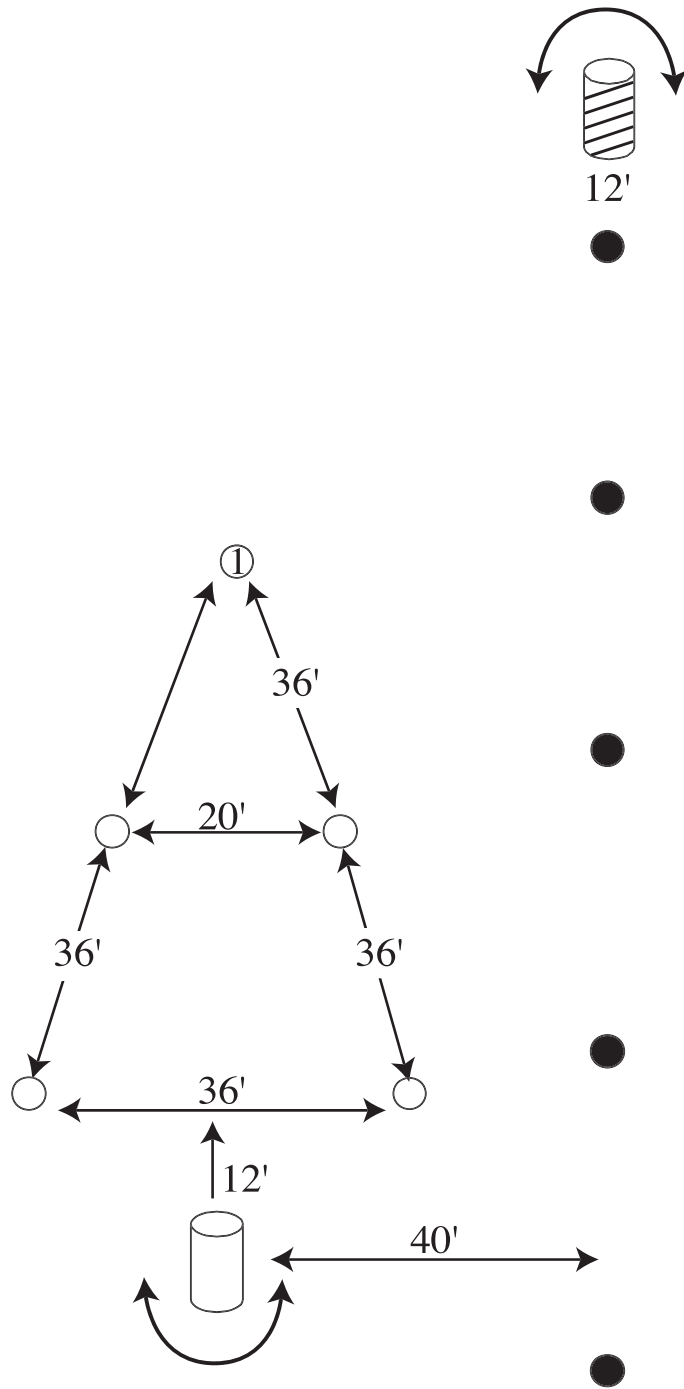

Start/Finish

#15

- A. Shoot the farthest light targets first
 - B. Shoot all the light targets first, before rounding the barrel
- Procedurals: 1, 2, 3

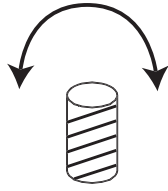

TTR

If two targets are burst by gun fire with the same round it is not a miss. Pole does not have to be shot. (Two Target Rule.



Start from either side

Start/Finish

#16

C. Shoot 5 of one color, round the barrel, shoot 5 of the other color

Procedurals: 3

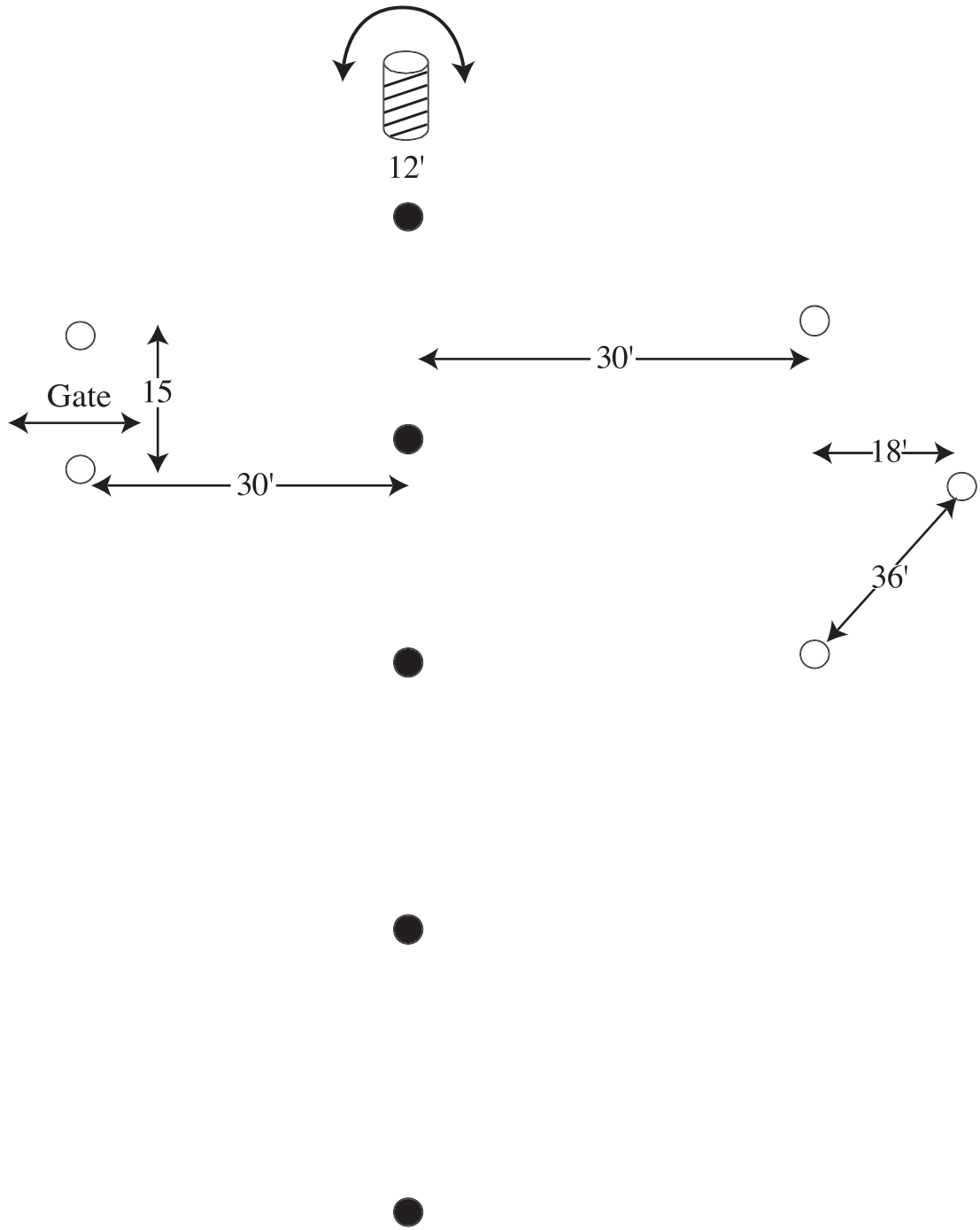

Start/Finish

#17

B. Shoot all the light targets first, before rounding the barrel

Procedurals: 2, 3, 4

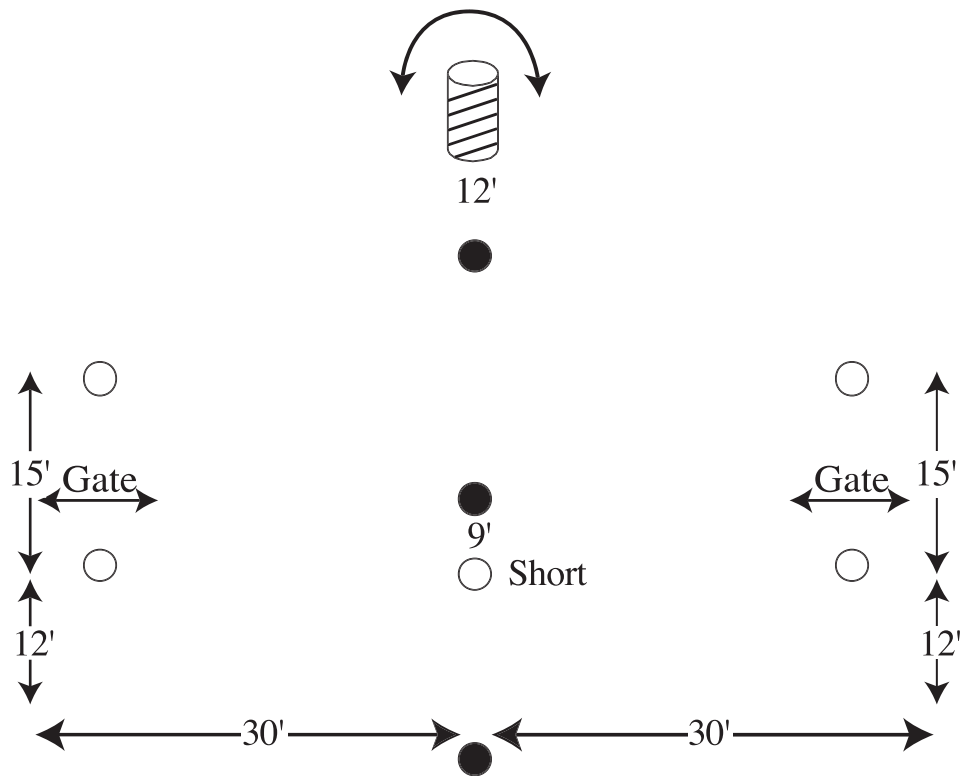

Start/Finish

#18

B. Shoot all the light targets first, before rounding the barrel

Procedurals: 3, 4

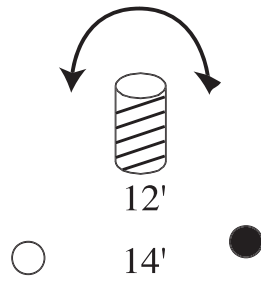

Start/Finish

#19

C. Shoot 5 of one color, round the barrel, shoot 5 of the other color
Procedurals: 3

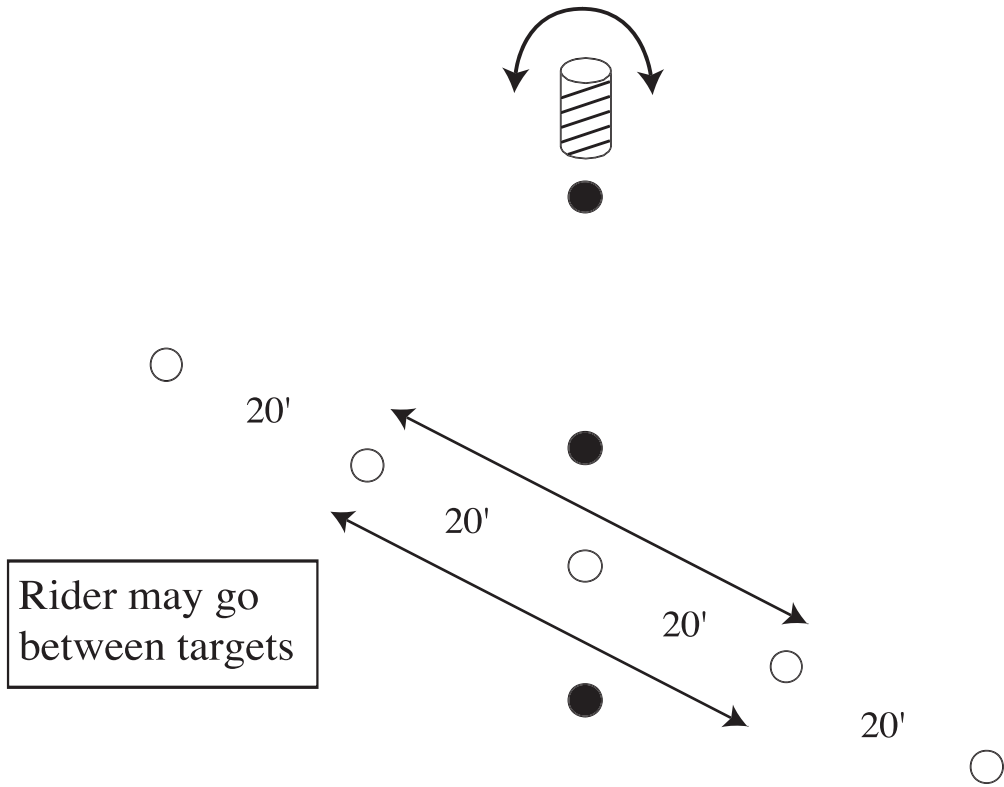

Start/Finish #20

B. Shoot all the light targets first, before rounding the barrel
 Procedurals: 2, 3

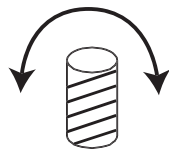

12'

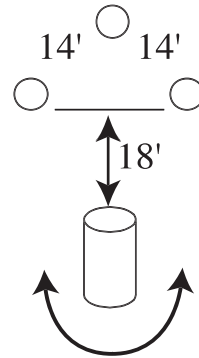
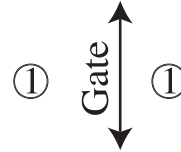

Start/Finish

#21

- A. Shoot the farthest light targets first
 - B. Shoot all the light targets first, before rounding the barrel
- Procedurals: 1, 2, 3, 4

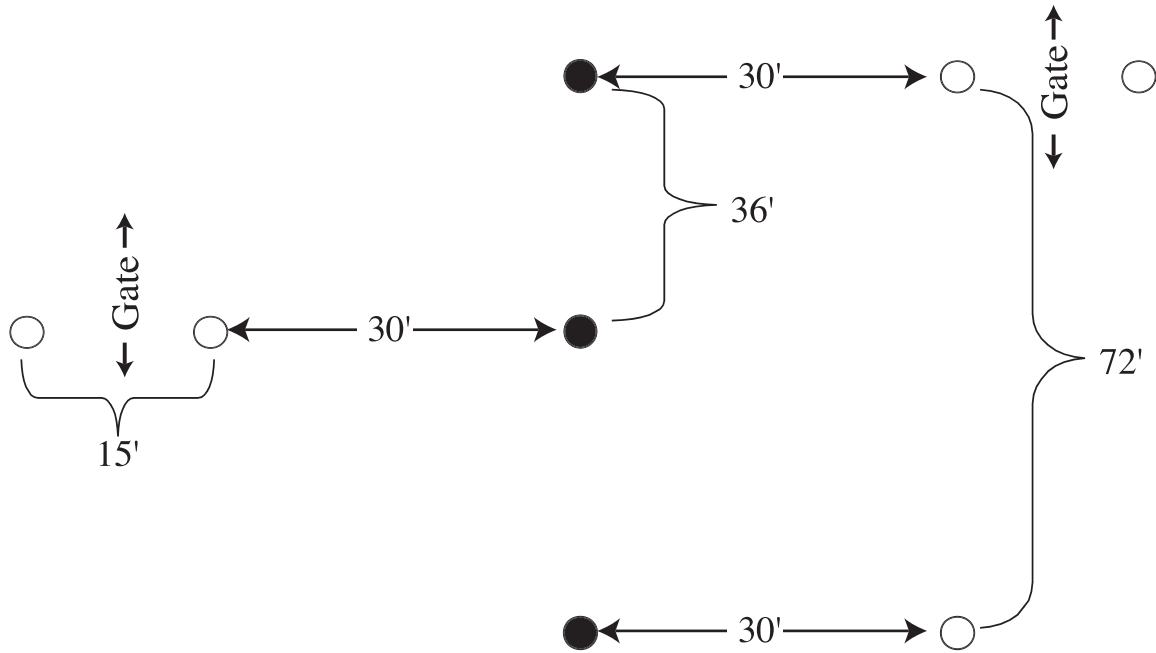
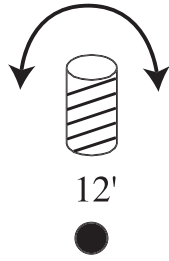

All poles are
48 inches tall

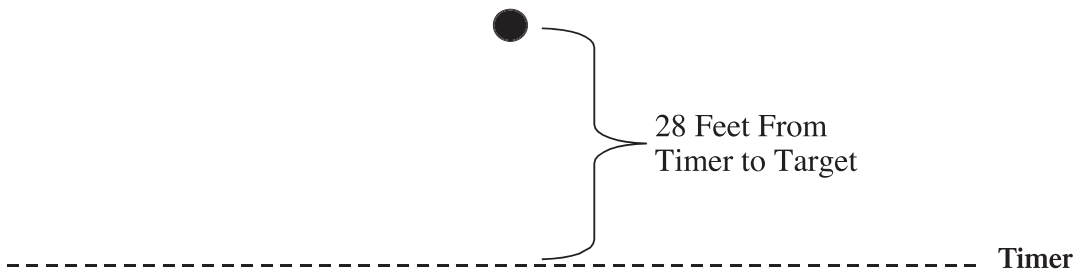

Course 22 - Certified

B. Shoot all the light targets first, before rounding the barrel

Procedurals: 2, 3, 4

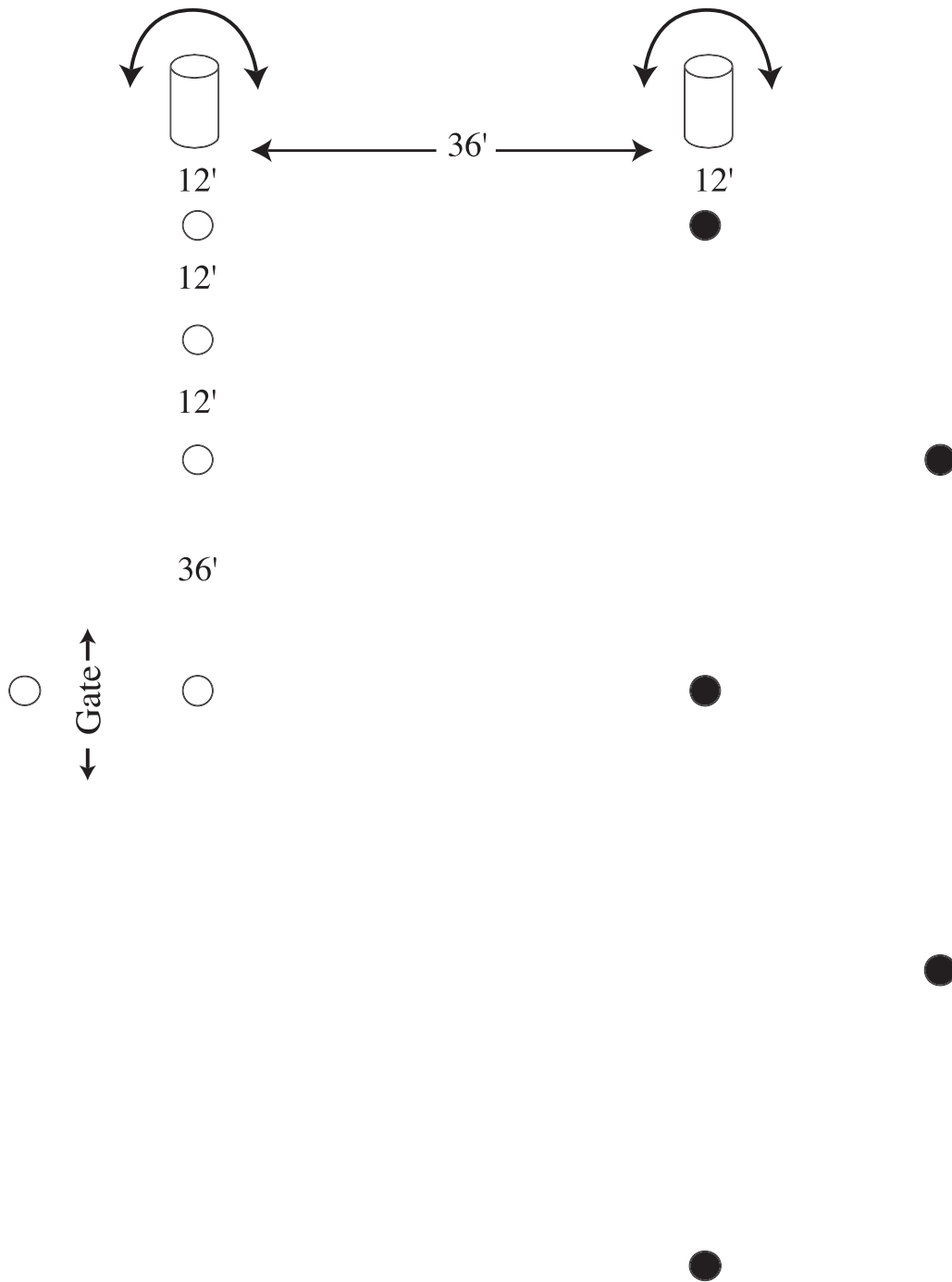

Start/Finish

#23

B. Shoot all the light targets first, before rounding the barrel

Procedurals: 2, 3, 4

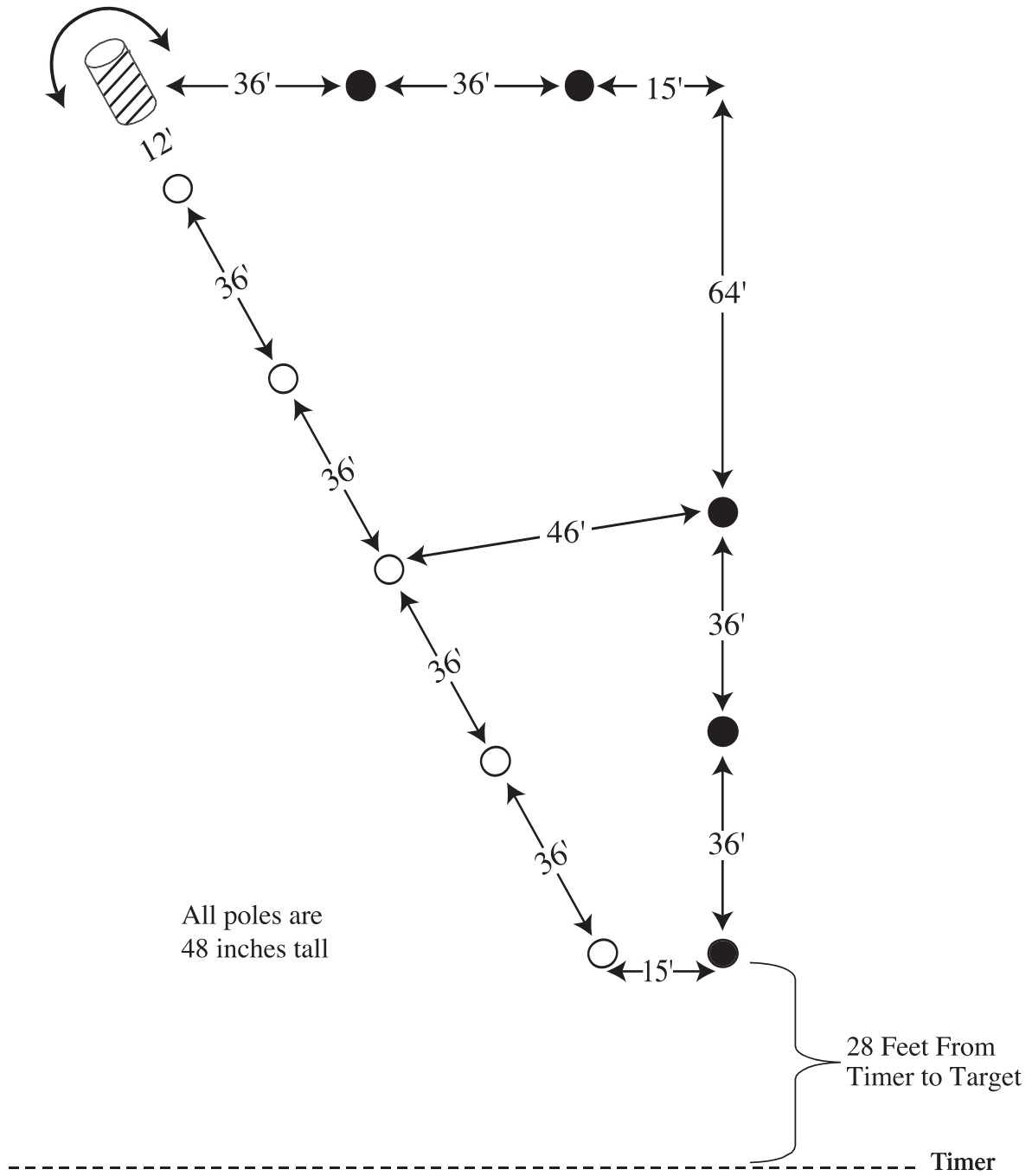

Course 24 - Certified

B. Shoot light targets first, then round the Rundown barrel

Procedurals: 2, 3

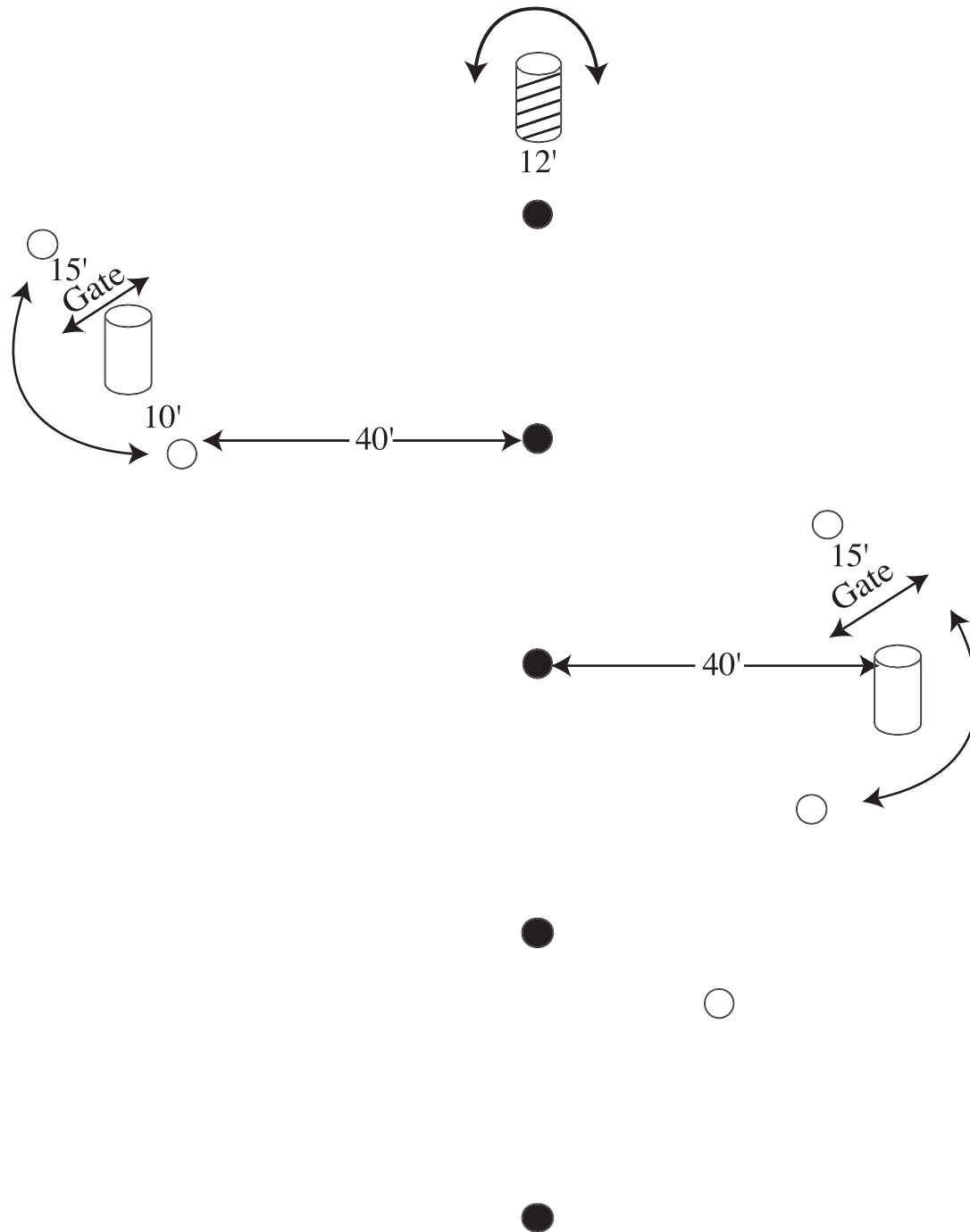

Start/Finish

#25

H. Shoot the entire Random course first, then round the Rundown barrel

Procedurals: 2, 3, 4

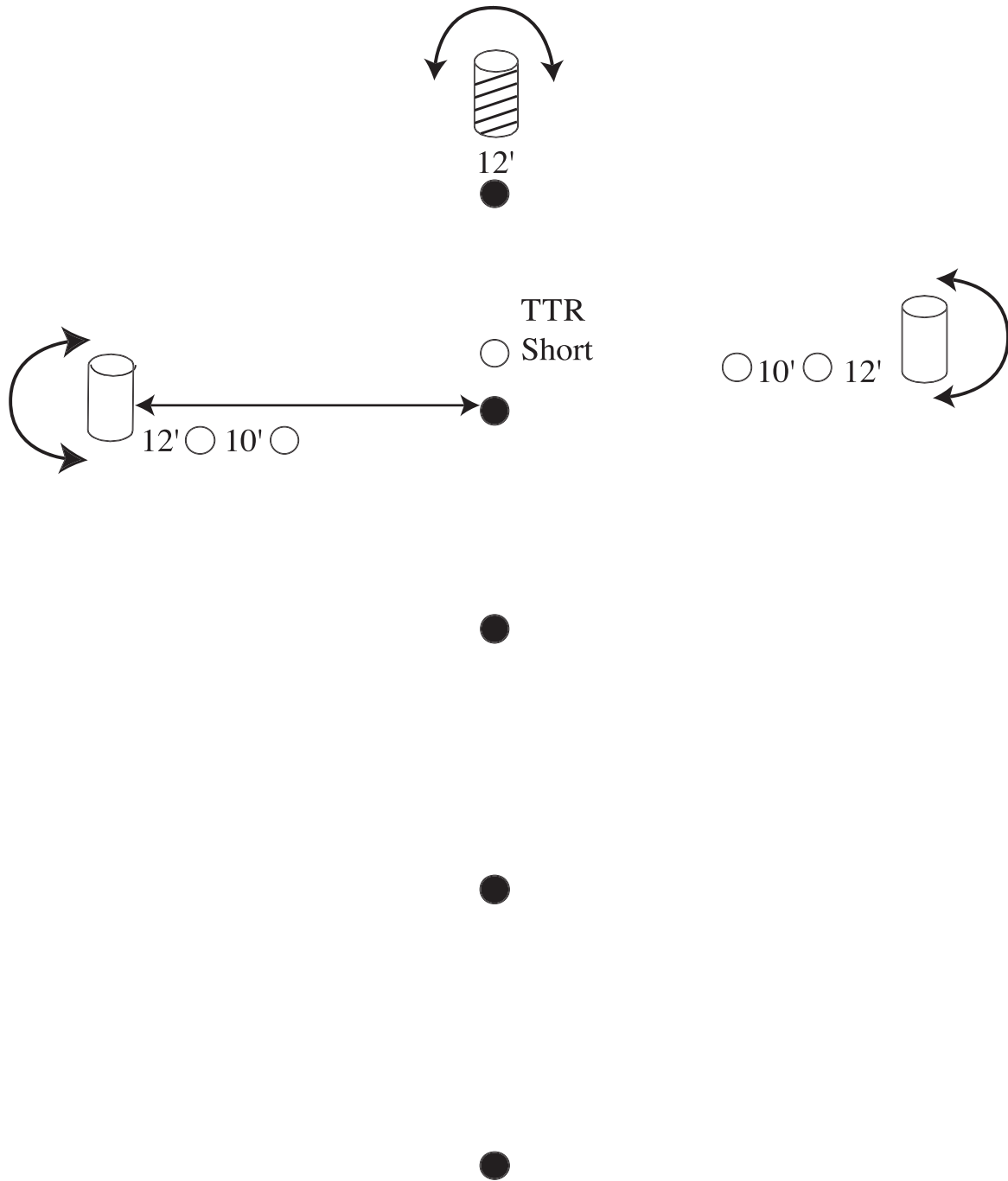

Start/Finish

#26

H. Shoot the entire Random course first, then round the Rundown barrel
 Procedurals: 2, 3

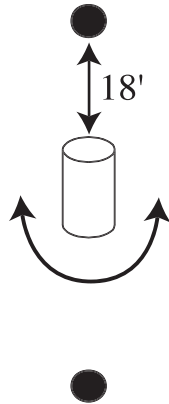
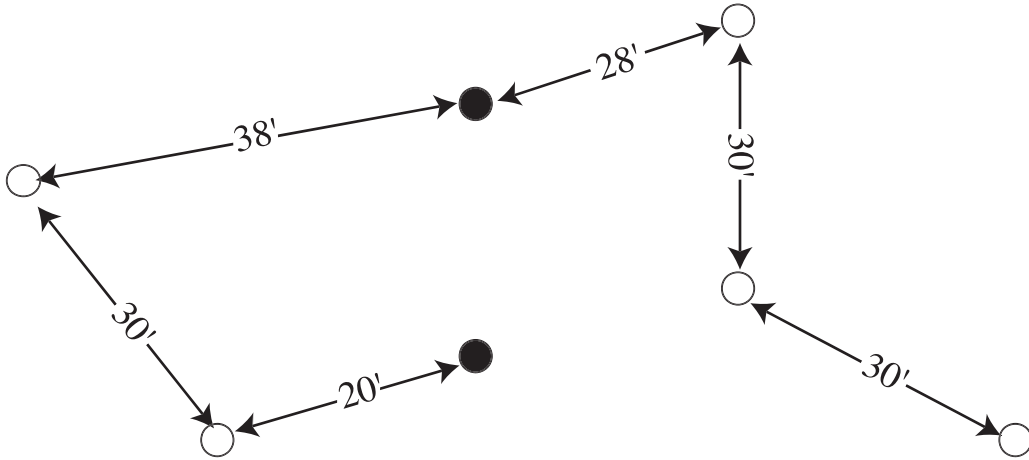
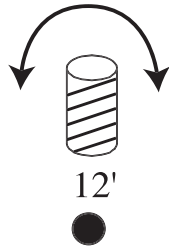

Start/Finish

 #27

B. Shoot all the light targets first, before rounding the barrel
 Procedurals: 2, 3

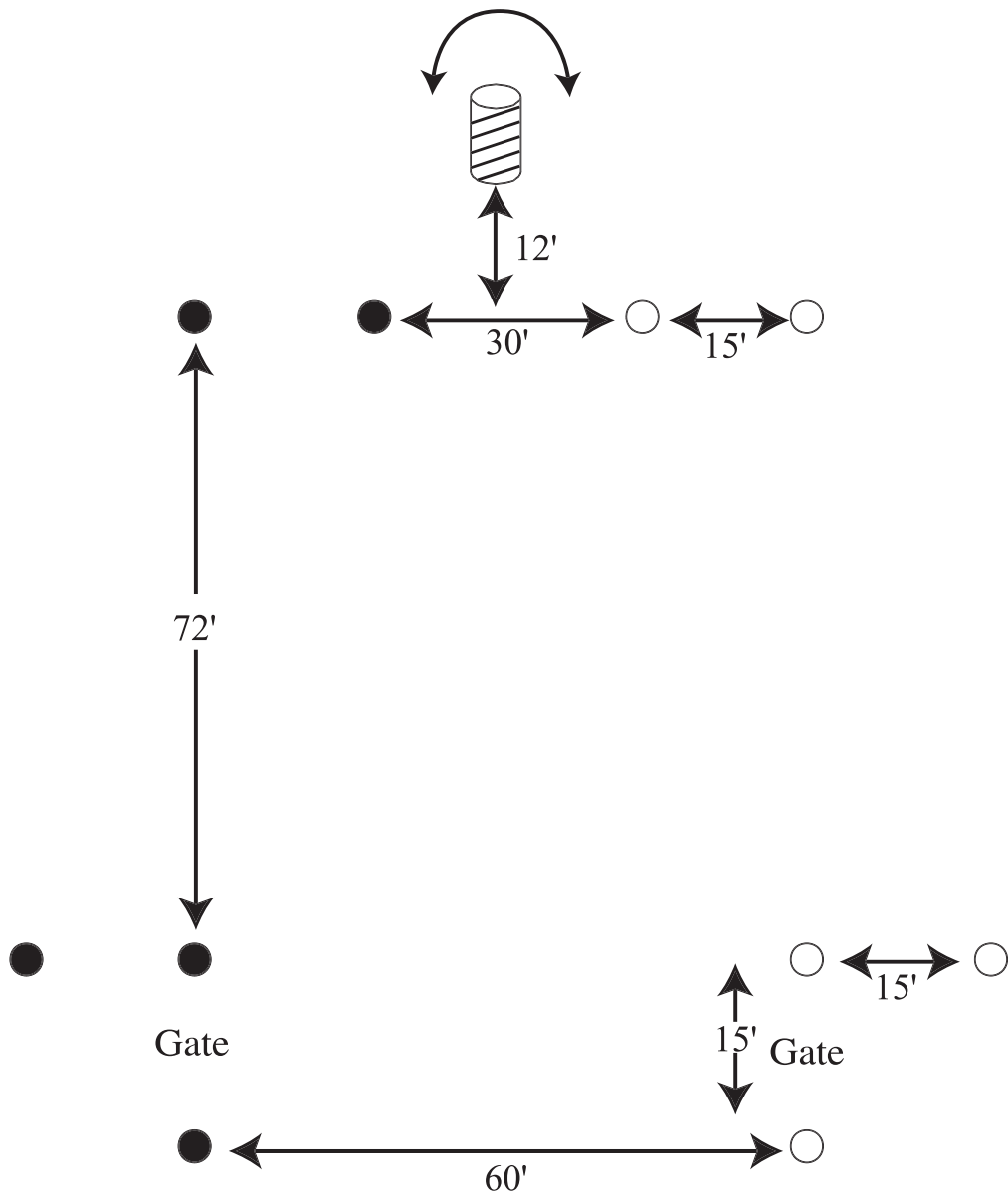

Start/Finish

#28

C. Shoot 5 of one color, round the barrel, shoot 5 of the other color
 Procedurals: 1, 3, 4

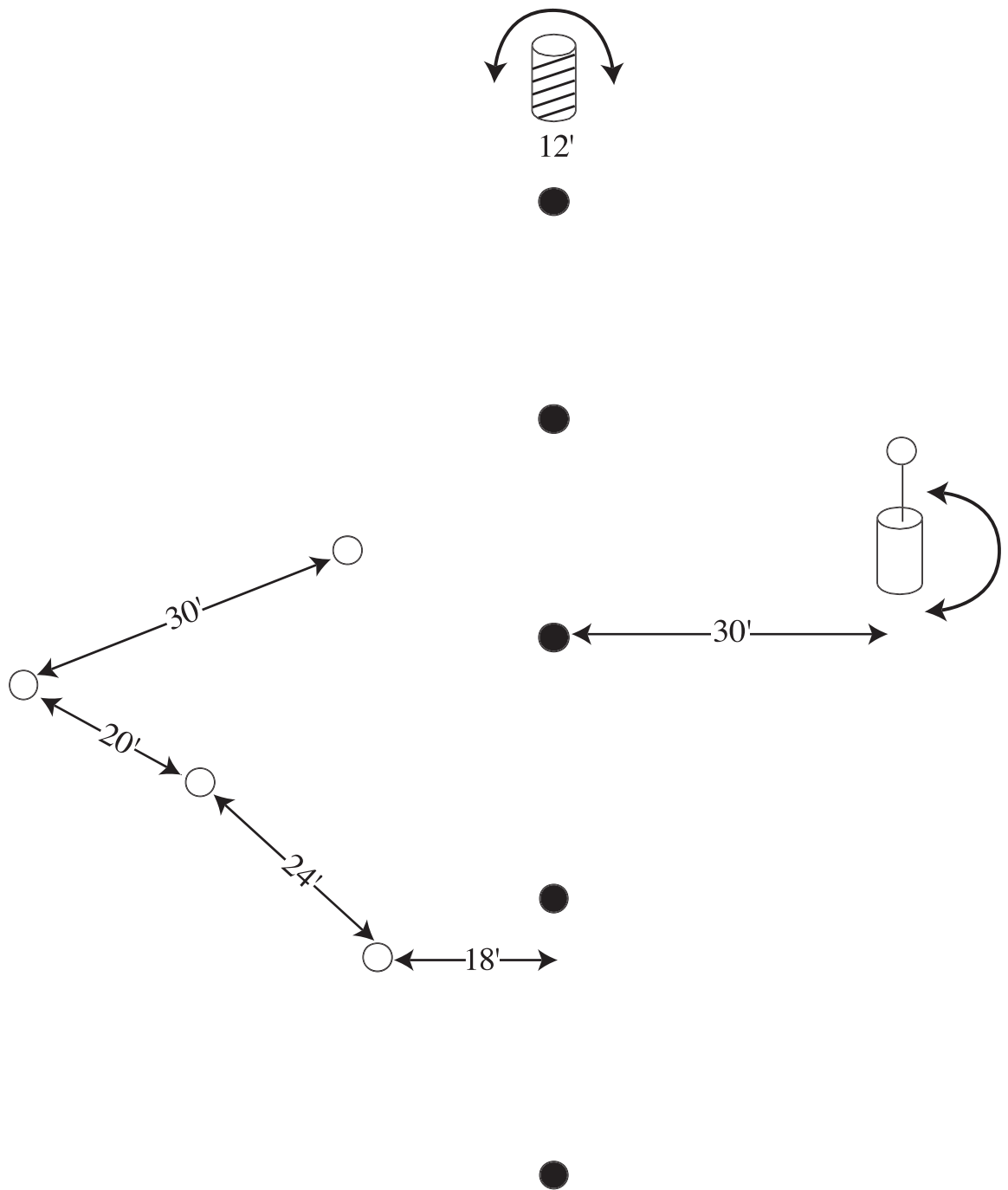

B. Shoot all the light targets first, before rounding the barrel
 Procedurals: 2, 3

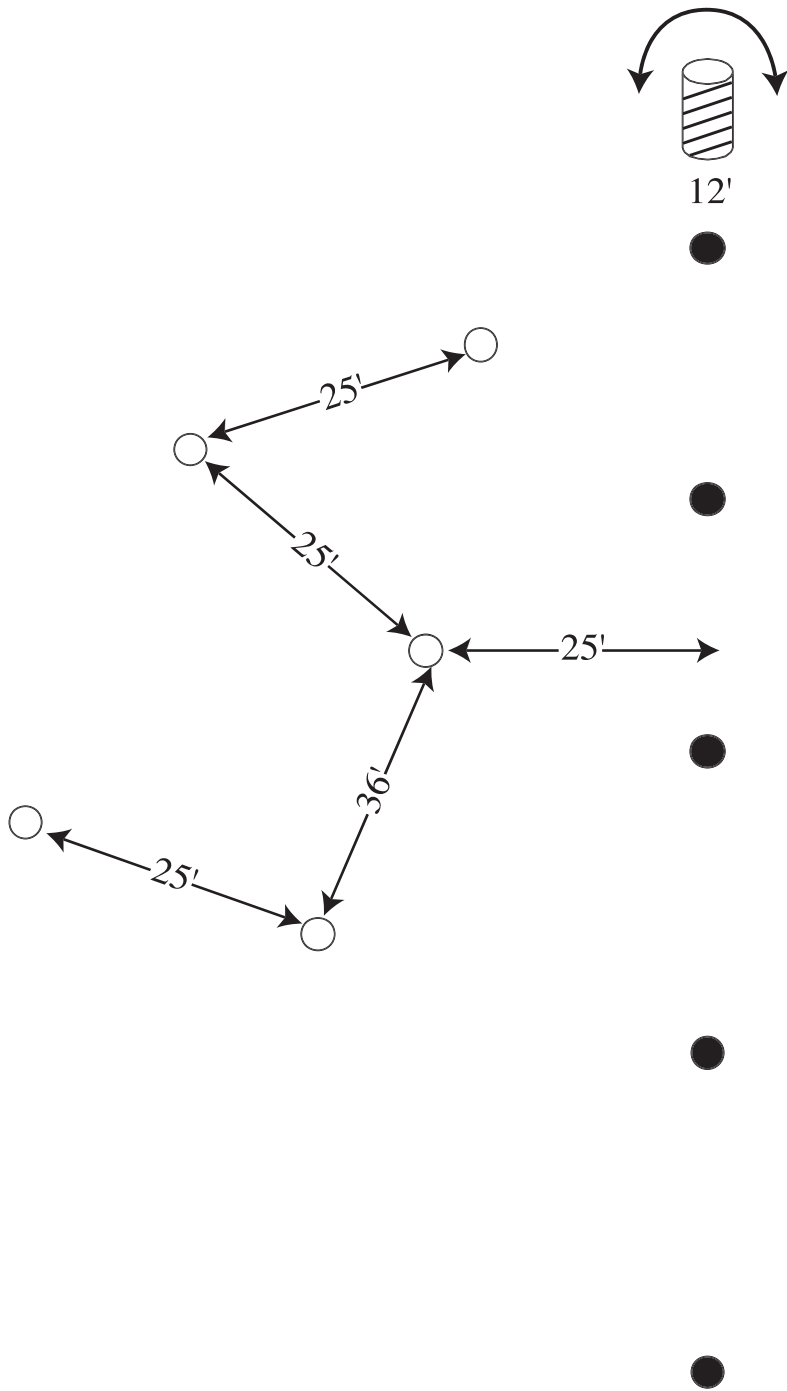

Start/Finish

#30

B. Shoot all the light targets first, before rounding the barrel

Procedurals: 2, 3

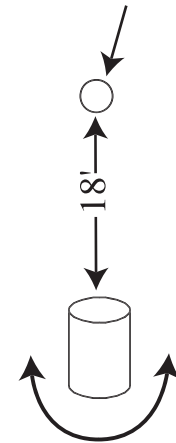
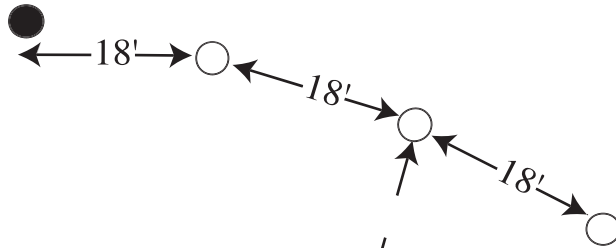
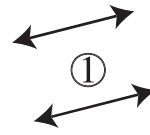
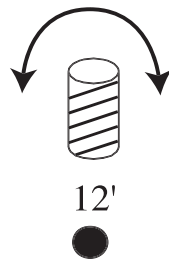

Start/Finish

#31

- A. Shoot the farthest light targets first
 - B. Shoot all the light targets first, before rounding the barrel
- Procedurals: 1, 2, 3,

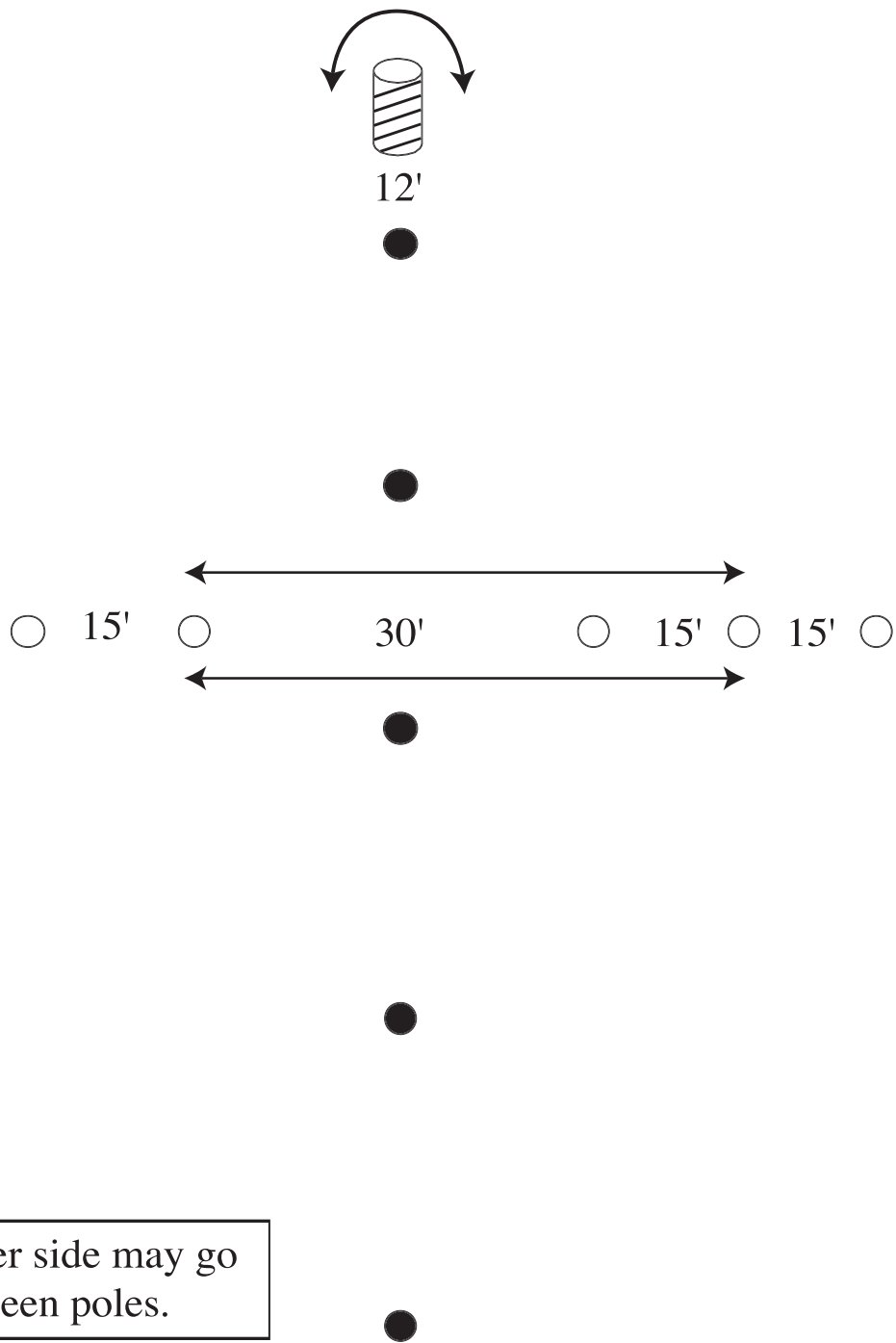

Start/Finish #32

B. Shoot all the light targets first, before rounding the barrel
 Procedurals: 2, 3

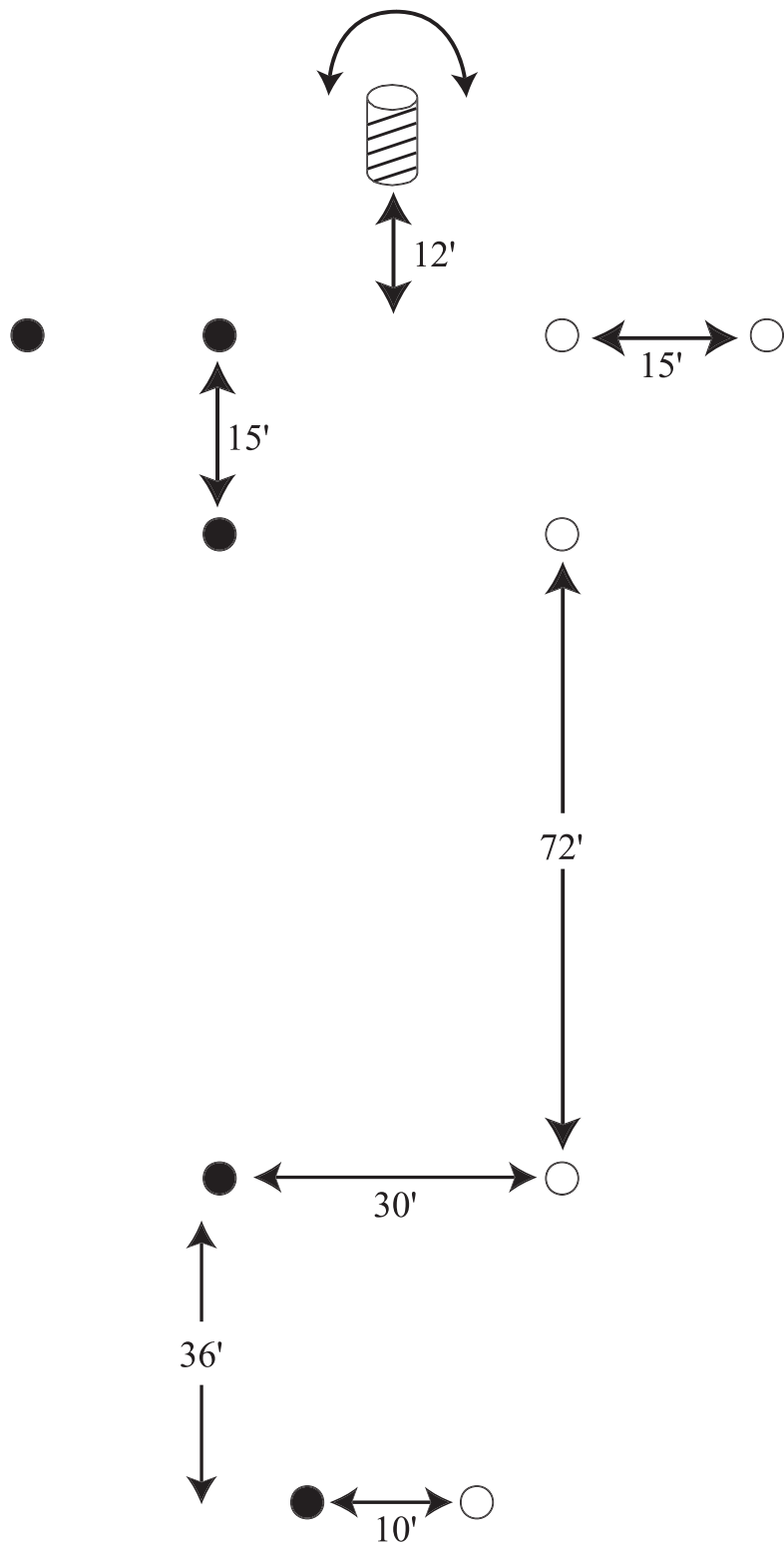

Start/Finish

#33

C. Shoot 5 of one color, round the barrel, shoot 5 of the other color
 Procedurals: 1, 3

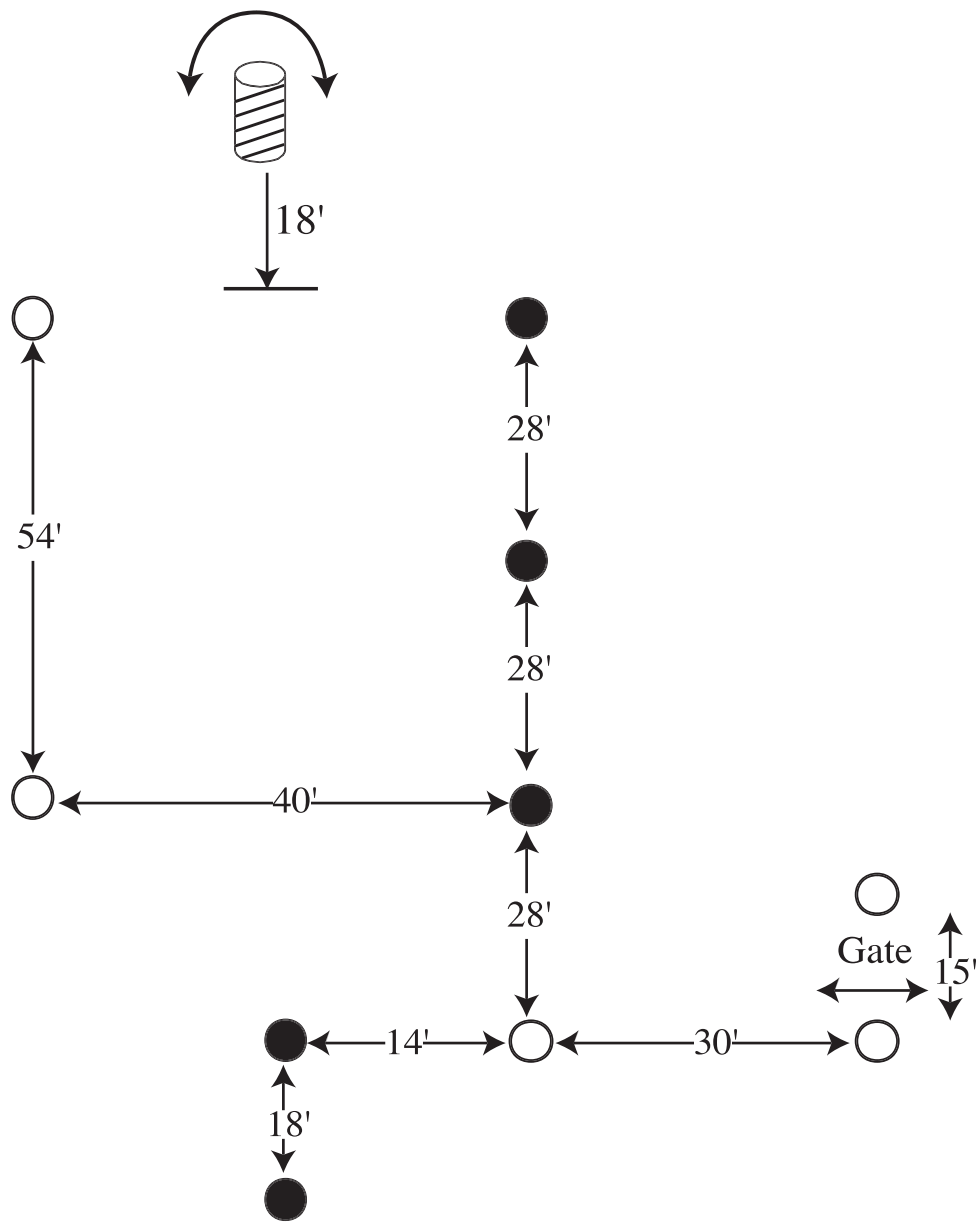

Start/Finish

 #34

B. Shoot all the light targets first, before rounding the barrel
 Procedurals: 2, 3, 4

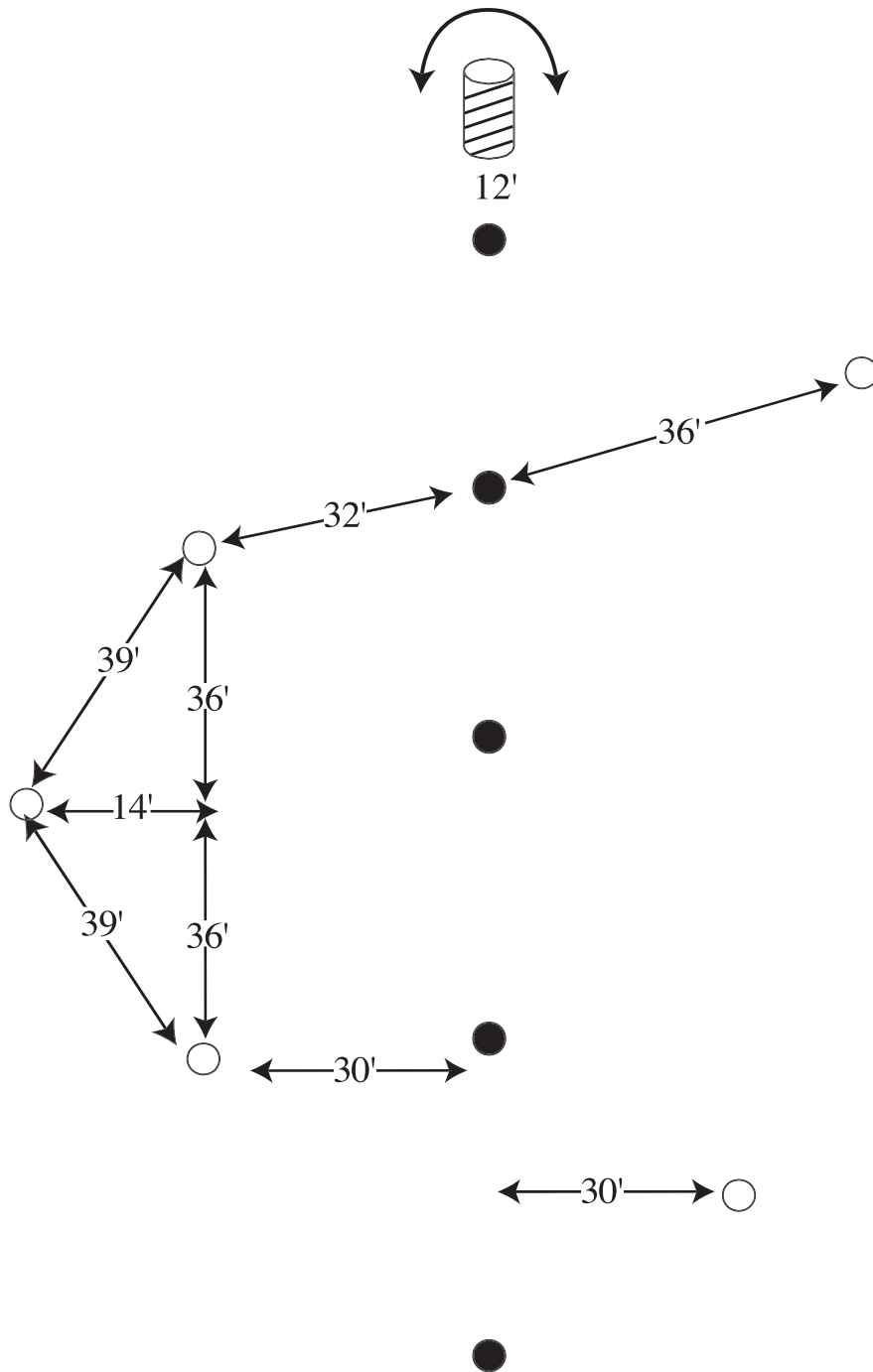

Start/Finish

#35

B. Shoot all the light targets first, before rounding the barrel

Procedurals: 2, 3

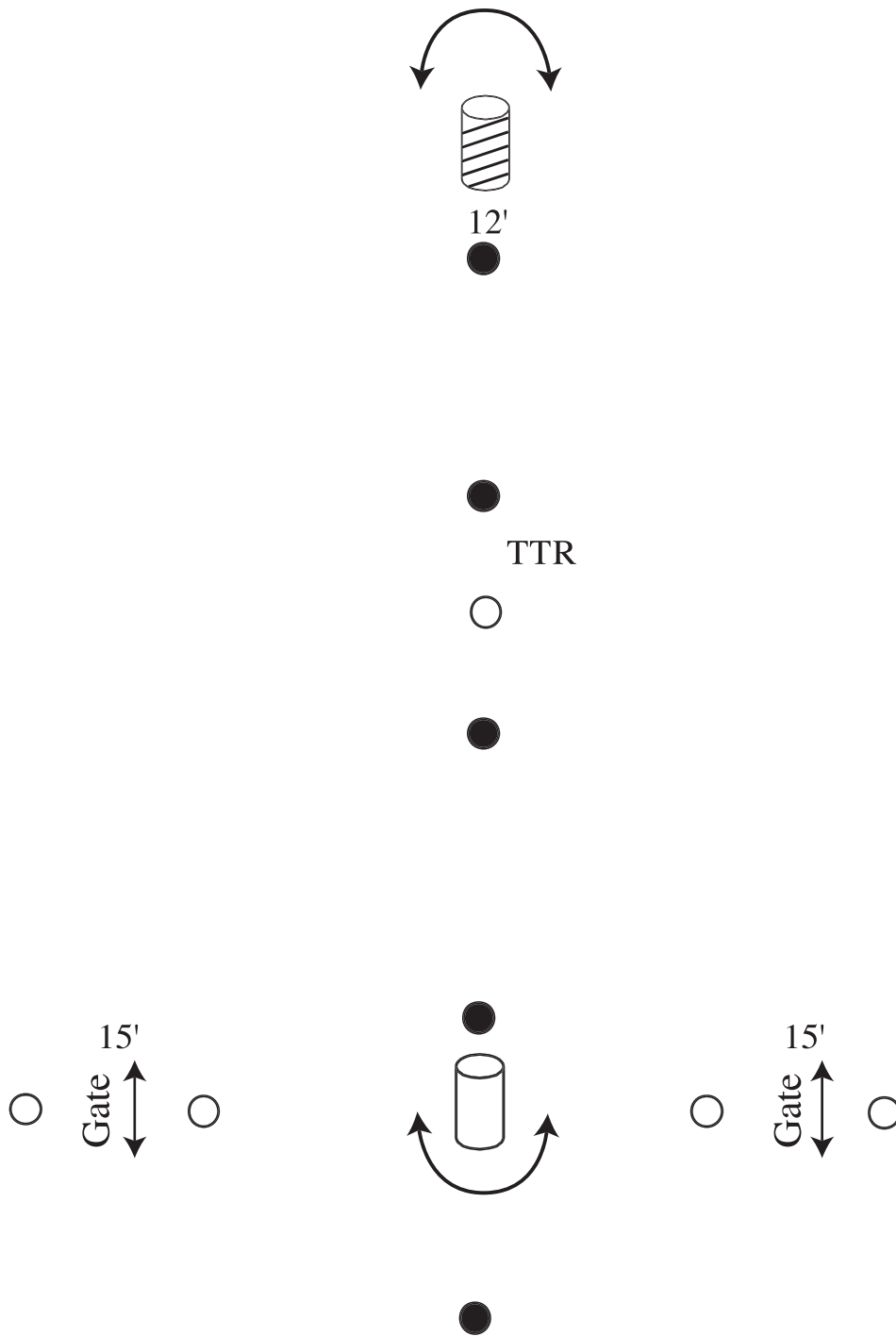

Start/Finish

#36

B. Shoot all the light targets first, before rounding the barrel

Procedurals: 2, 3, 4

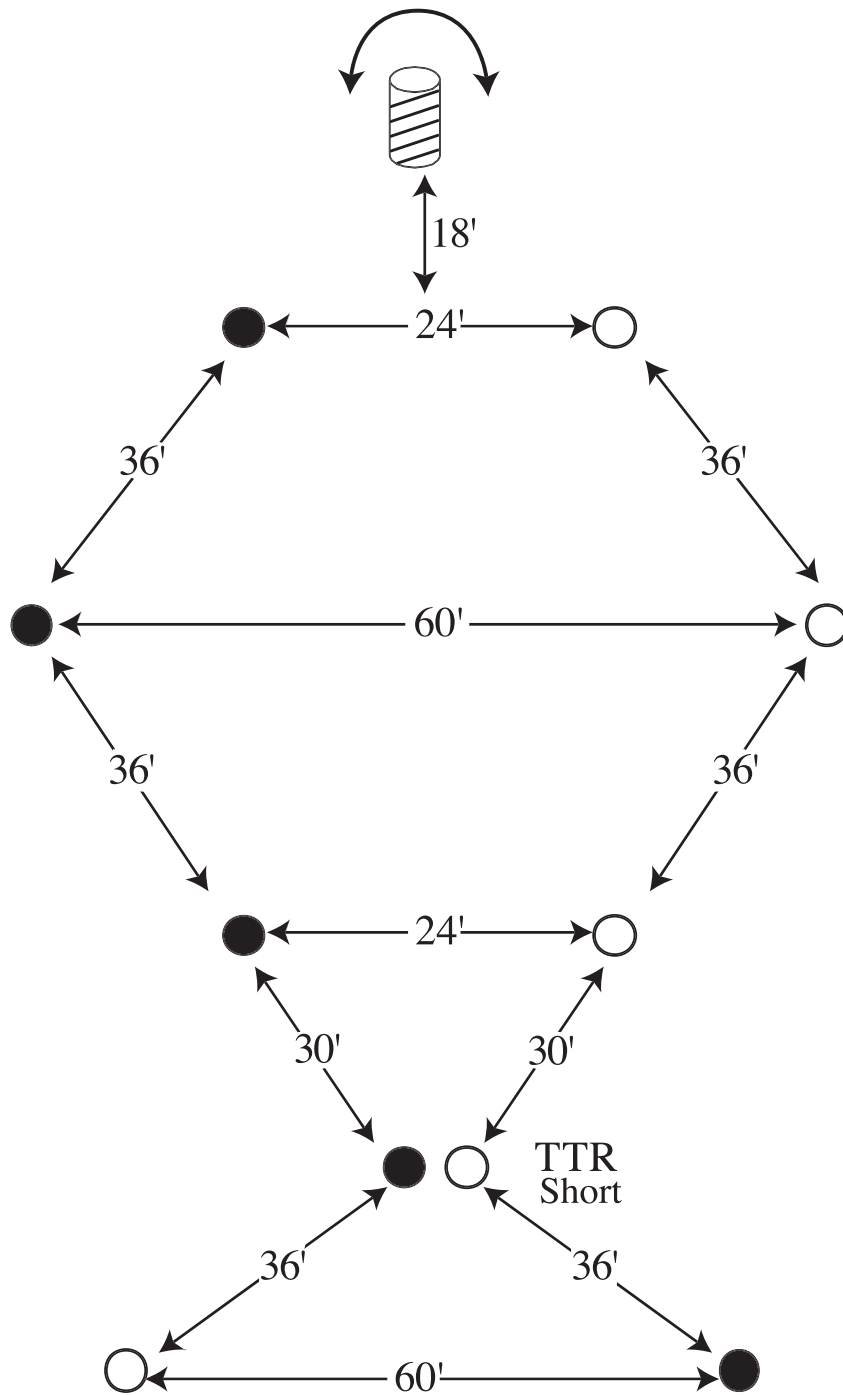

Start/Finish Line
#37

C. Shoot 5 of one color, round the barrel, shoot 5 of the other color
 Procedurals: 2, 3

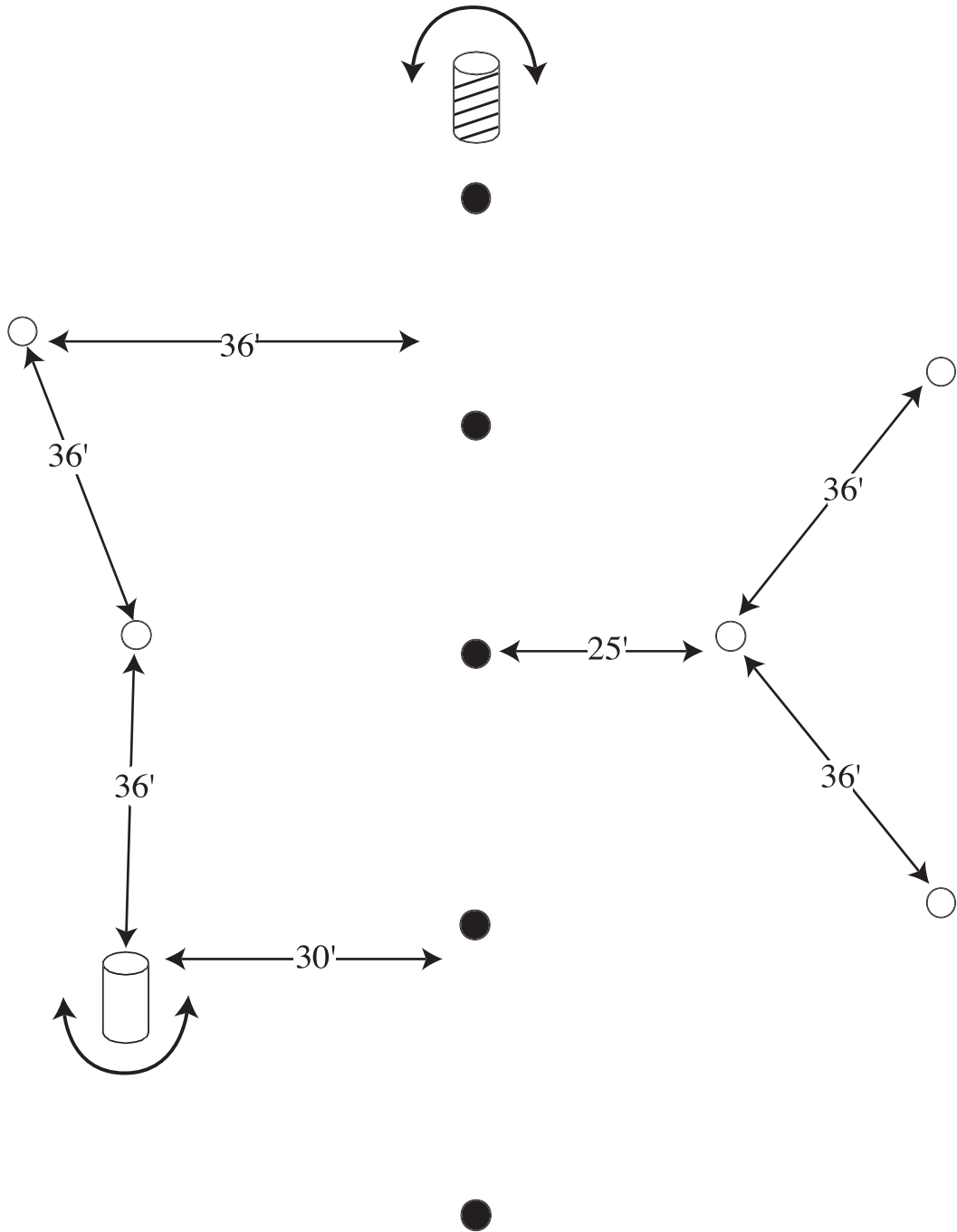

Start/Finish

#38

B. Shoot all the light targets first, before rounding the barrel

Procedurals: 2, 3

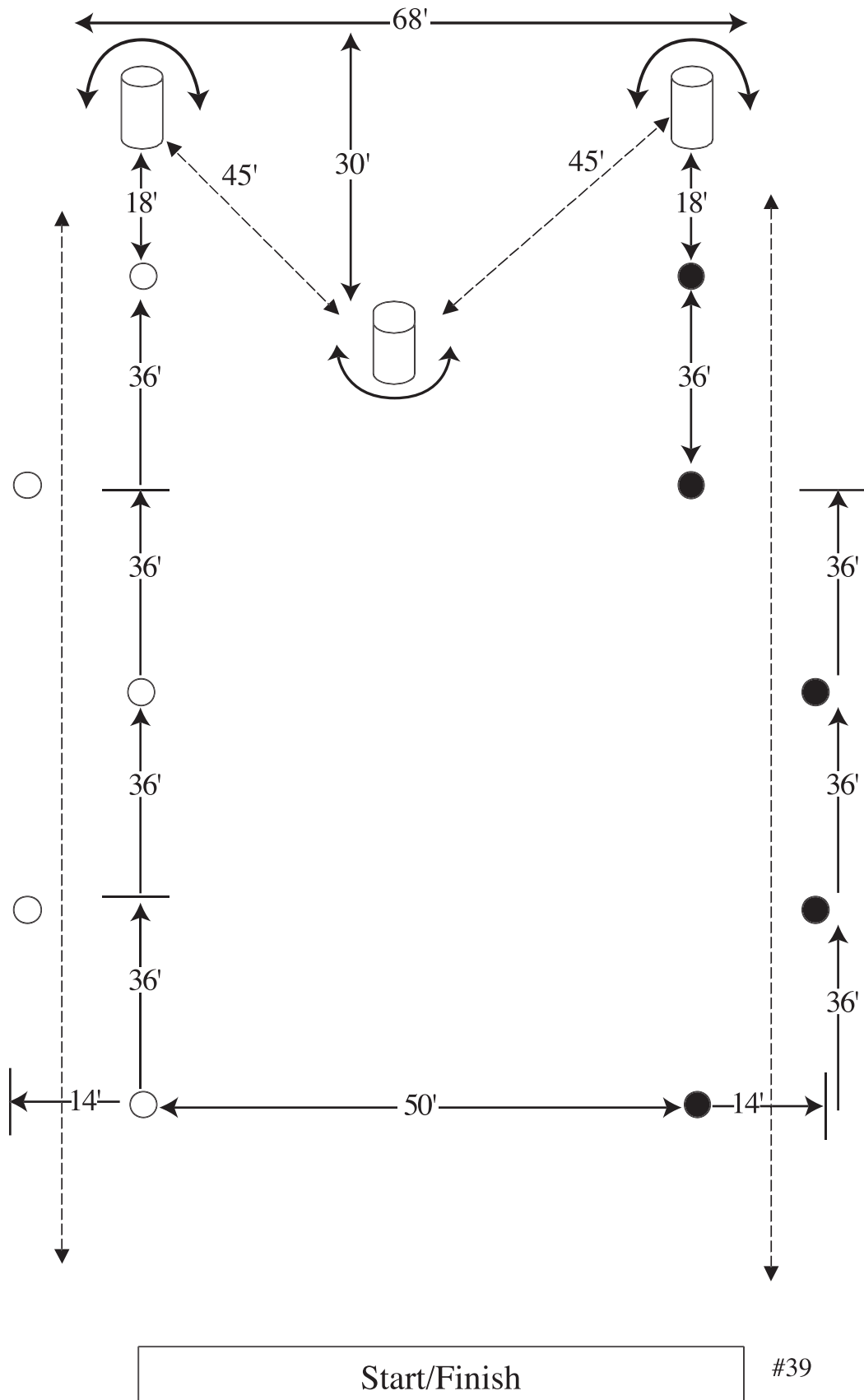

F. Shoot 5, round the barrel, round the barrel, round the barrel, shoot 5
 Procedurals: 2, 3, 5

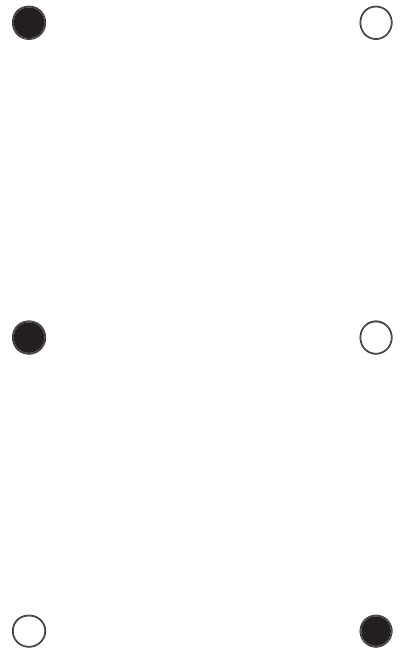
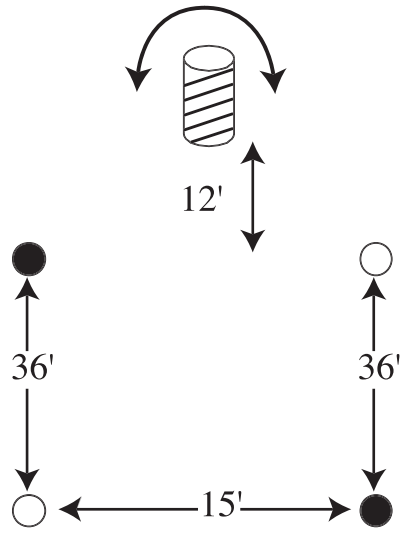

Start/Finish

 #40

C. Shoot 5 of one color, round the barrel, shoot 5 of the other color
 Procedurals: 2, 3

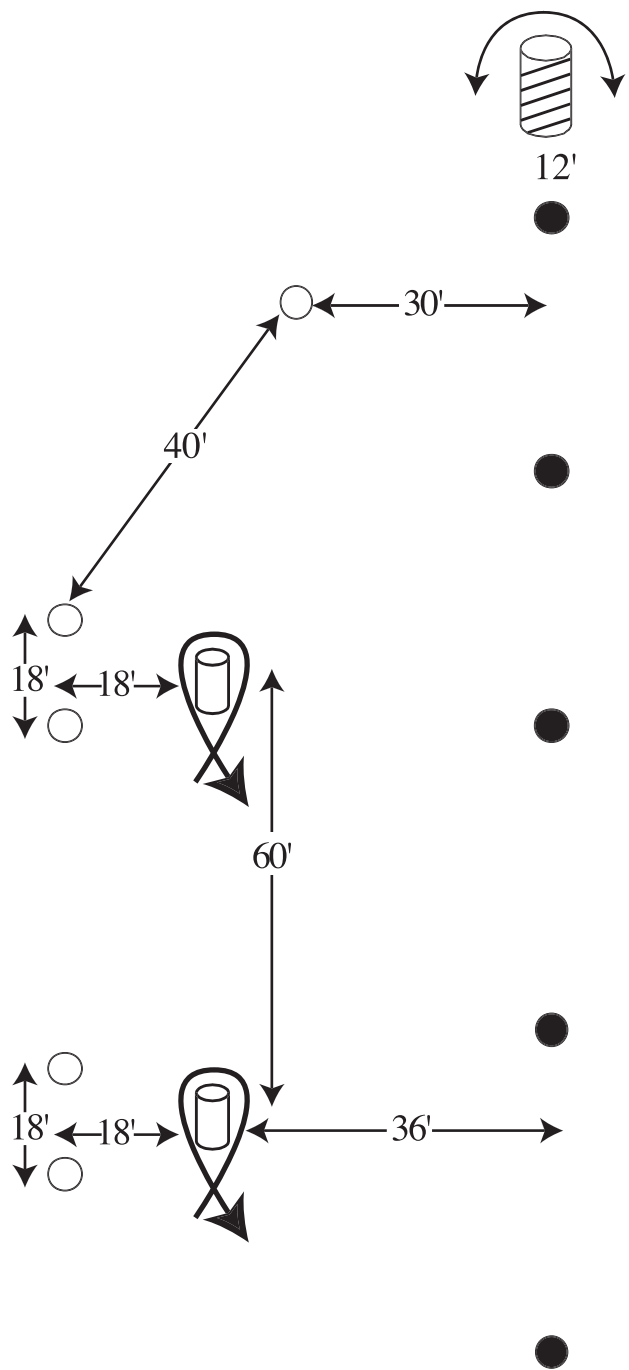

Start/Finish

#41

B. Shoot all the light targets first, before rounding the barrel

Procedurals: 2, 3

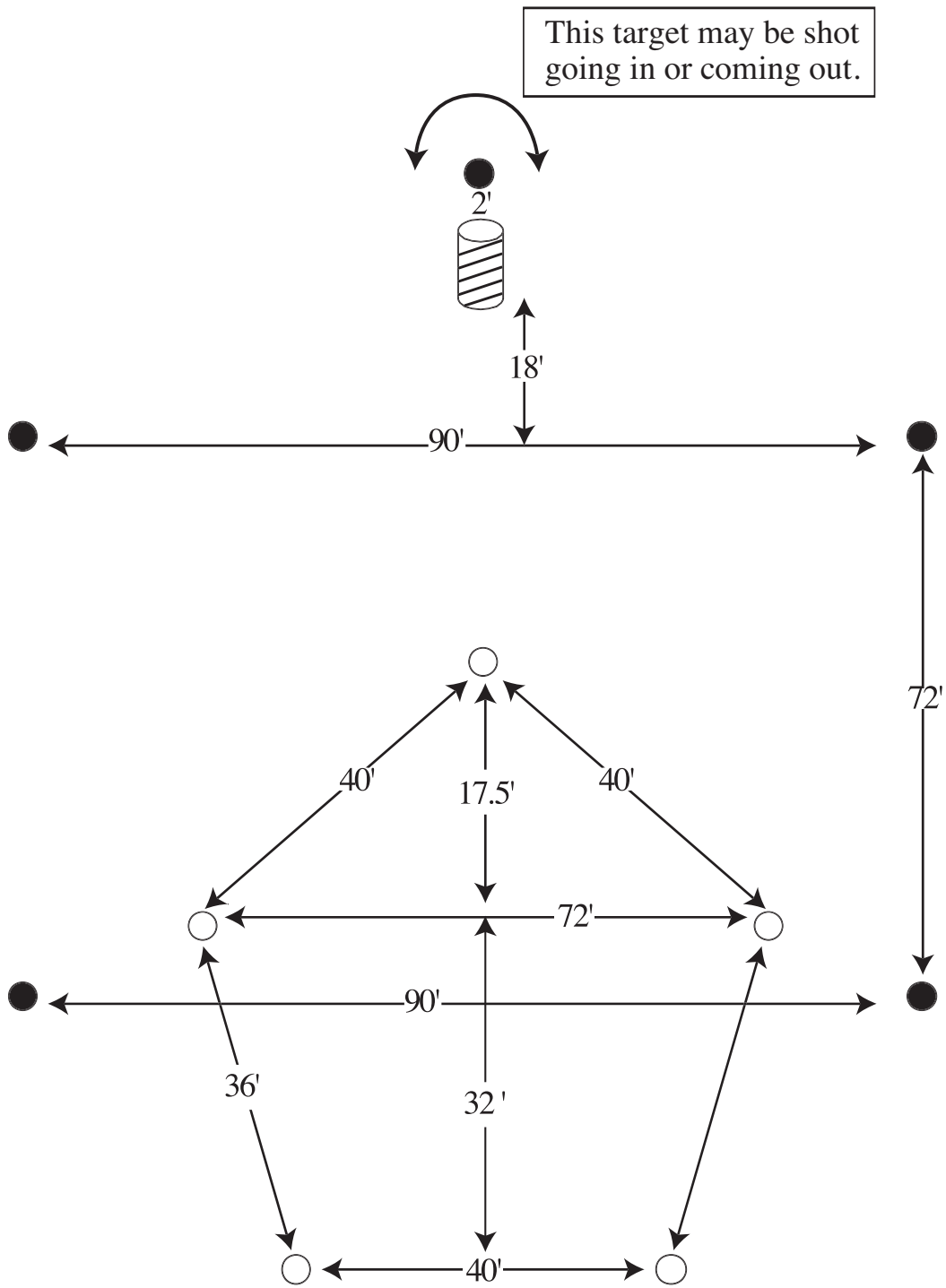

Start/Finish #42

I. Shoot all the light targets first. Then shoot the dark targets. You must round the barrel
 Procedurals: 1, 3

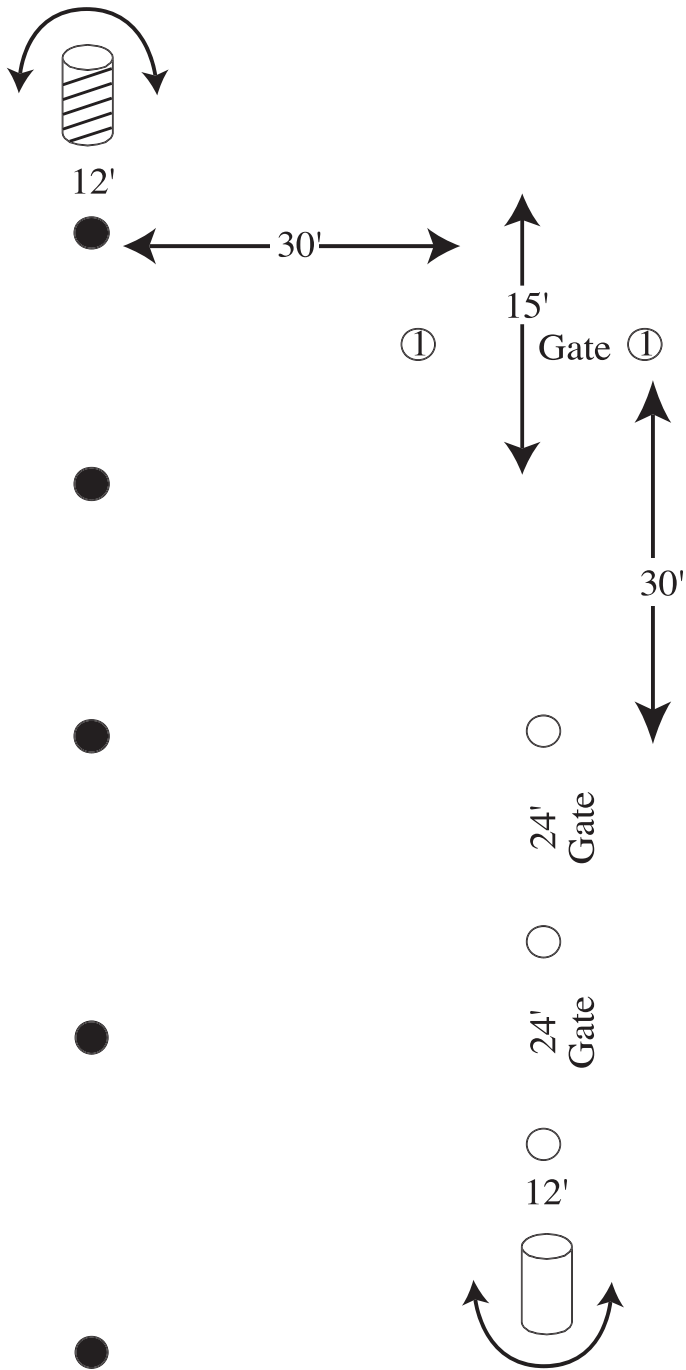

Start/Finish

#43

- A. Shoot the farthest light targets first
 - B. Shoot all the light targets first, before rounding the barrel
- Procedurals: 1, 2, 3, 4

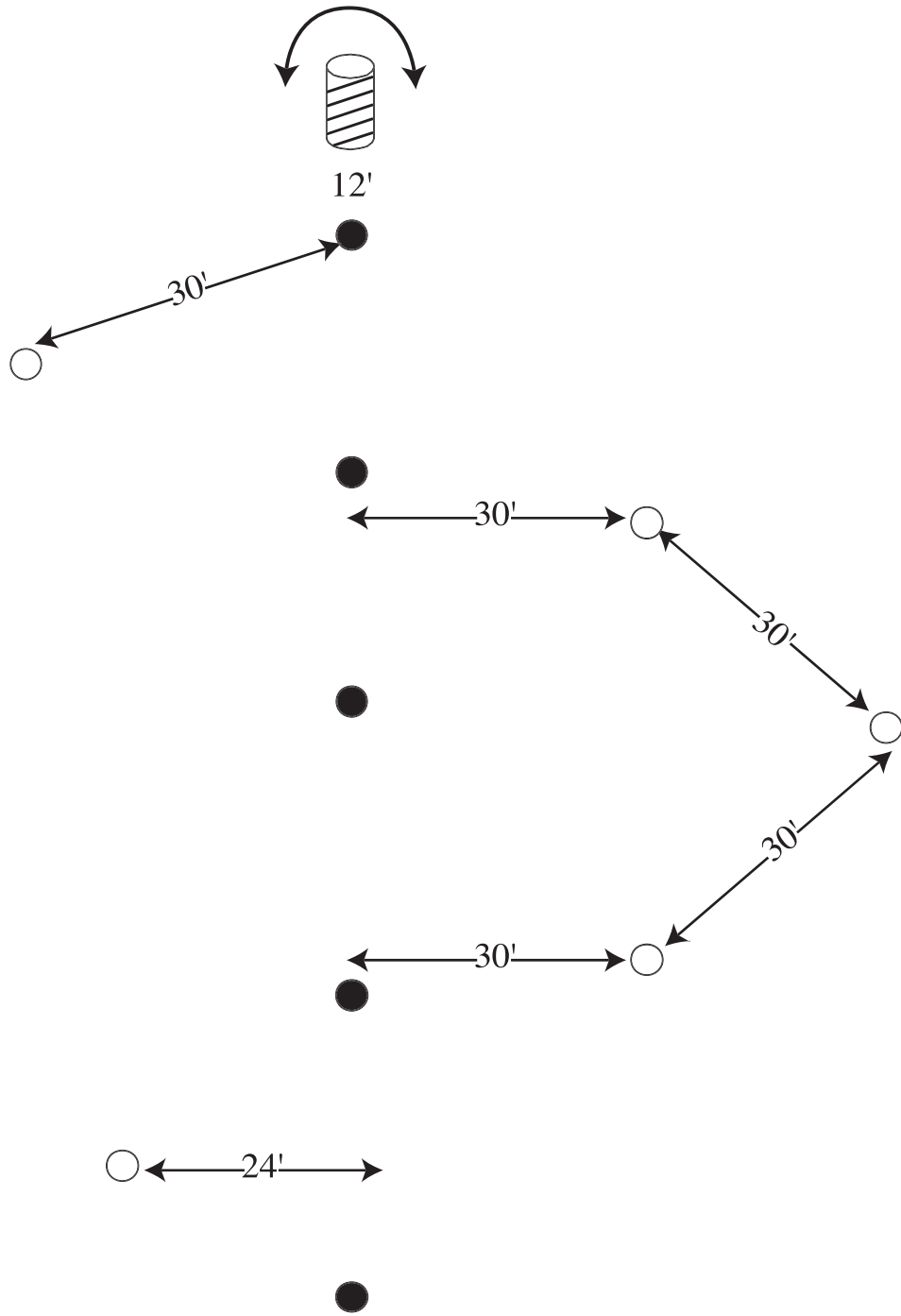

Start/Finish

#44

B. Shoot all the light targets first, before rounding the barrel

Procedurals: 2, 3

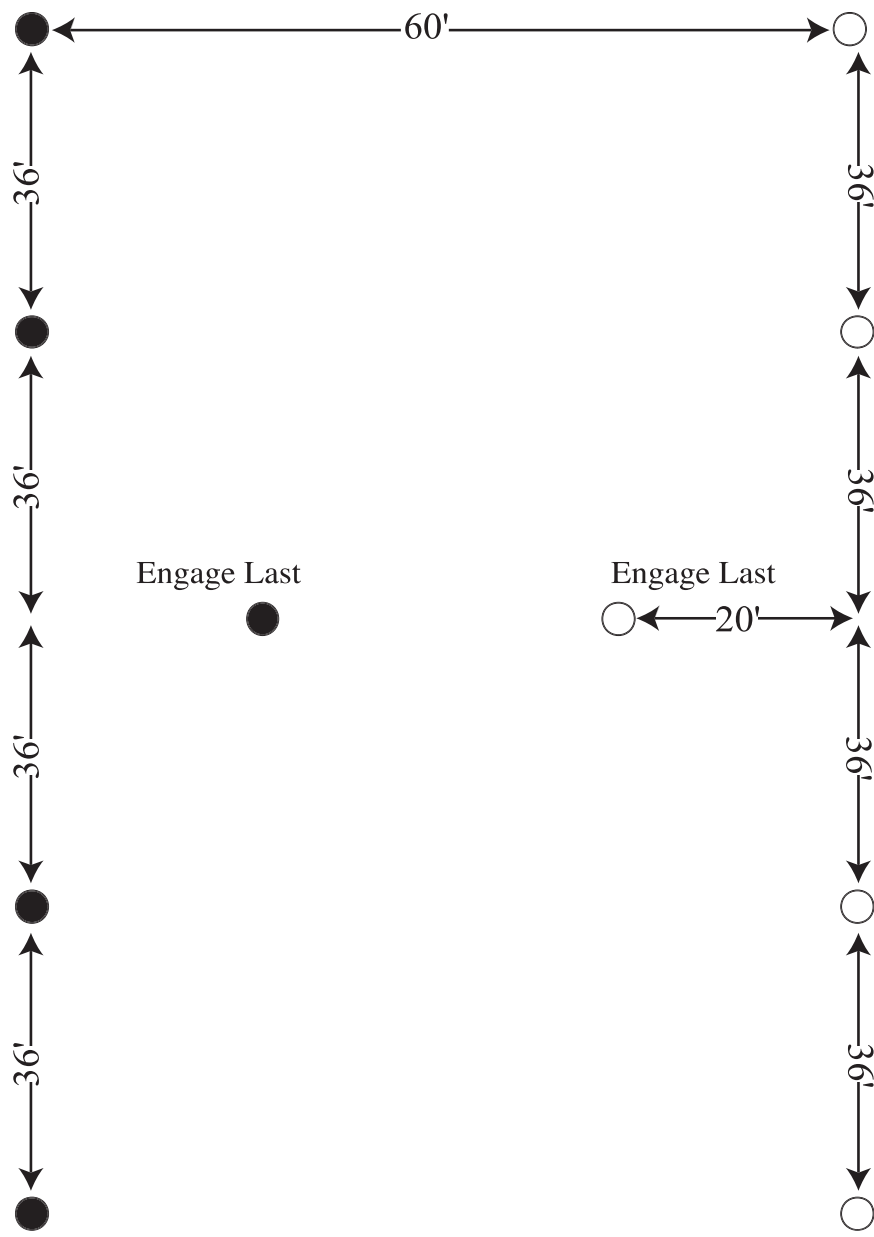

Start/Finish #45

G. Shoot light target last, shoot dark target last
 Procedurals: 5

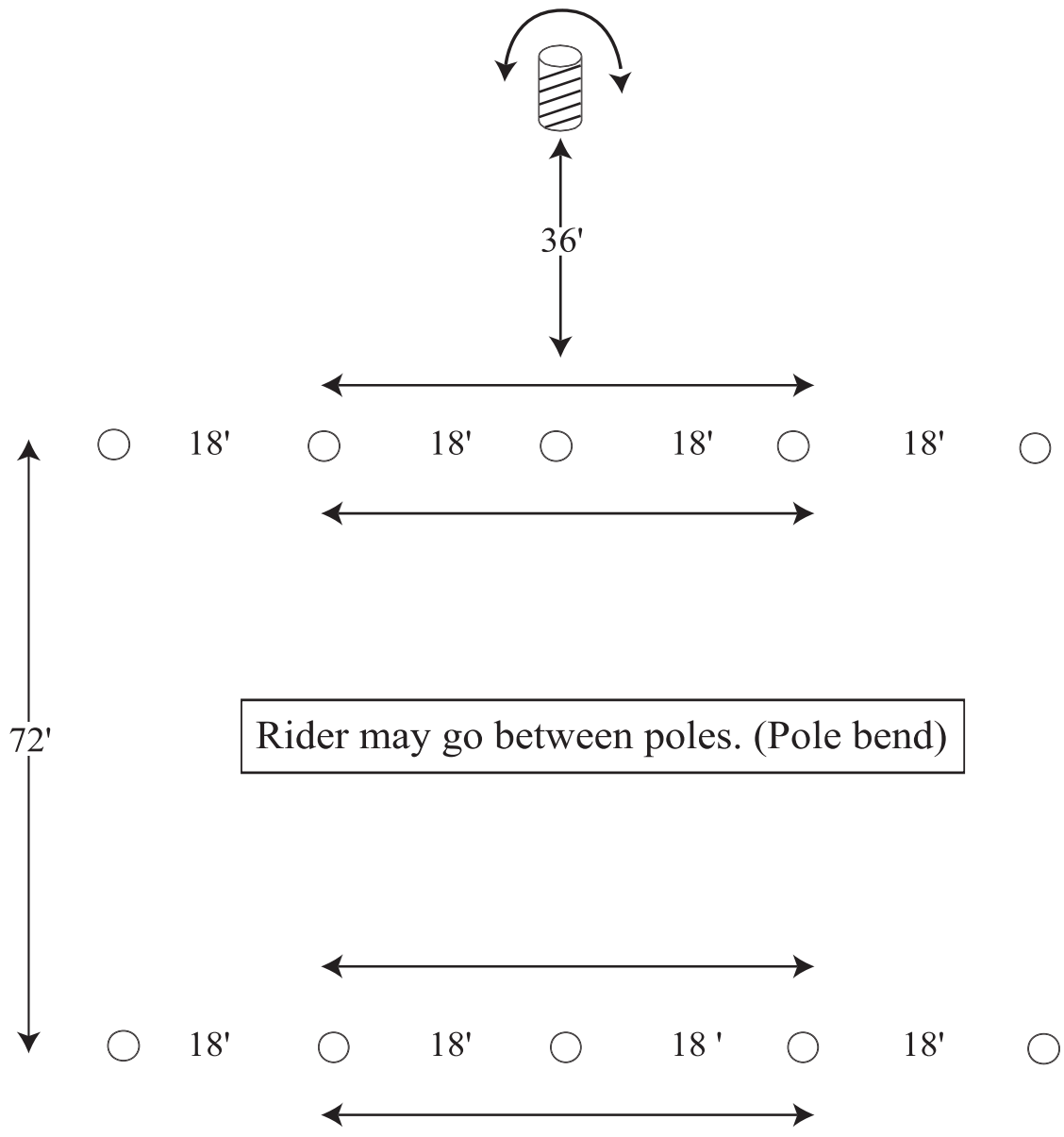

Rider may go between poles. (Pole bend)

Start/Finish

#46

B. Shoot all the targets first, before rounding the barrel
 Procedurals: 2, 3

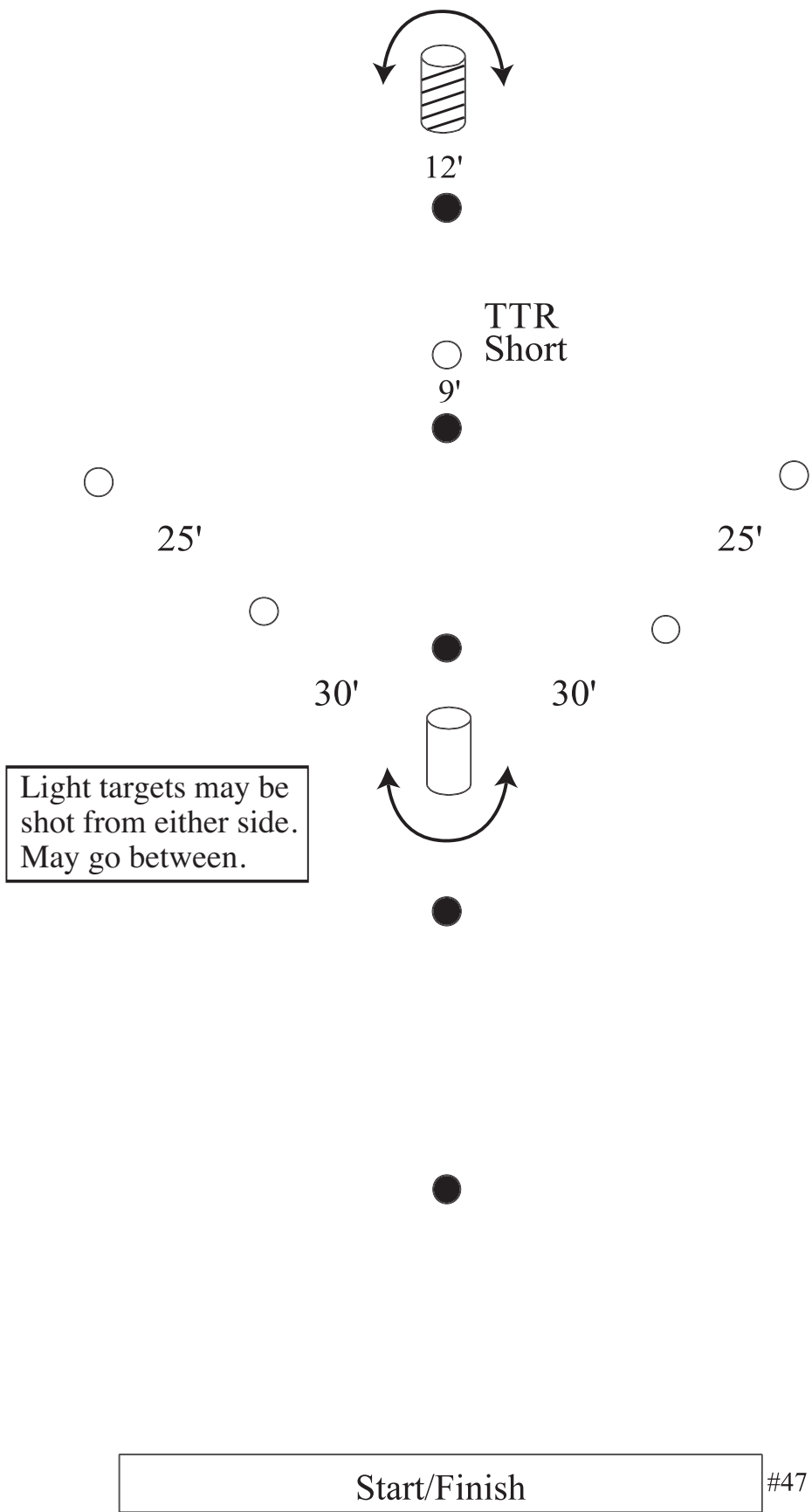

B. Shoot all the light targets first, before rounding the barrel
 Procedurals: 2, 3

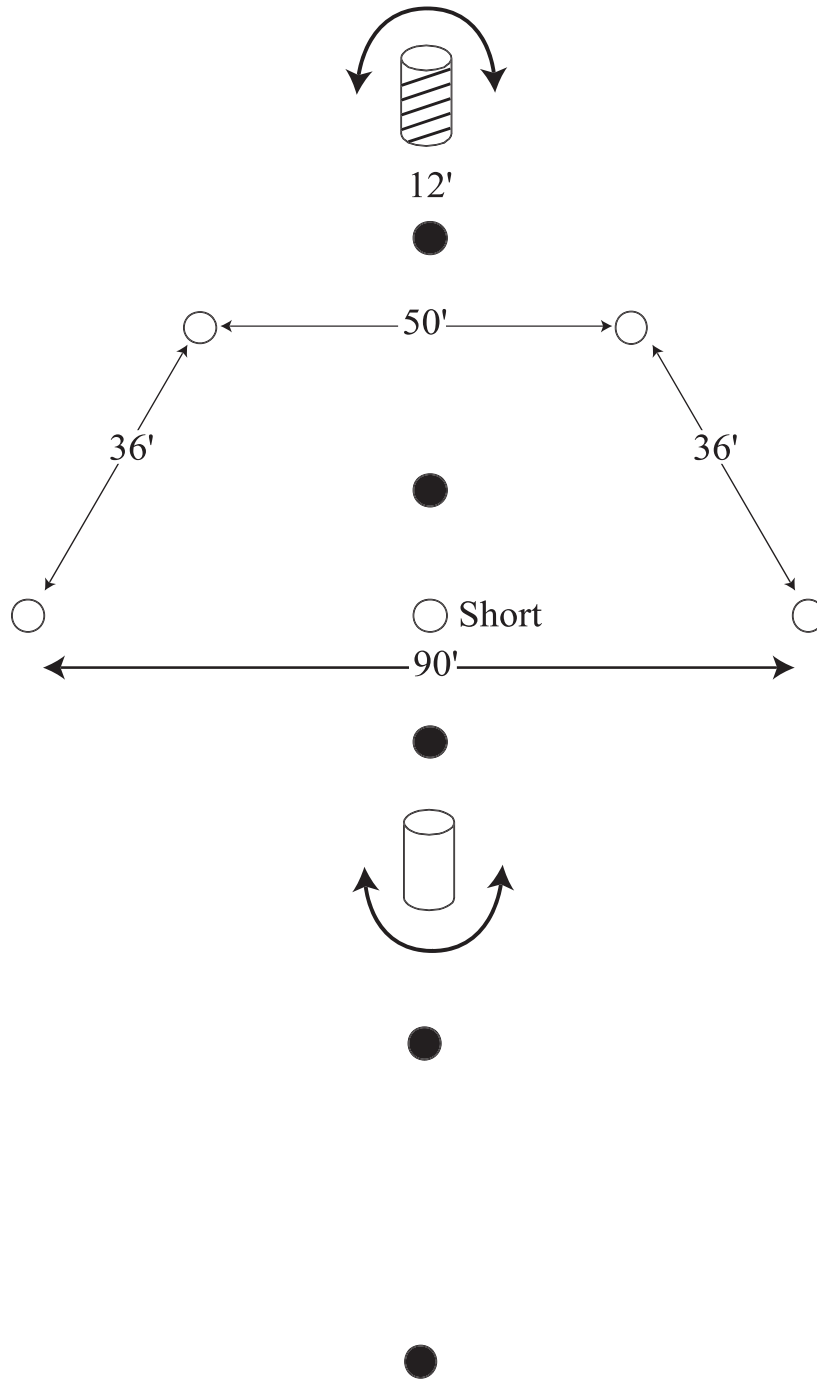

Start/Finish

#49

B. Shoot all the light targets first, before rounding the barrel

Procedurals: 2, 3

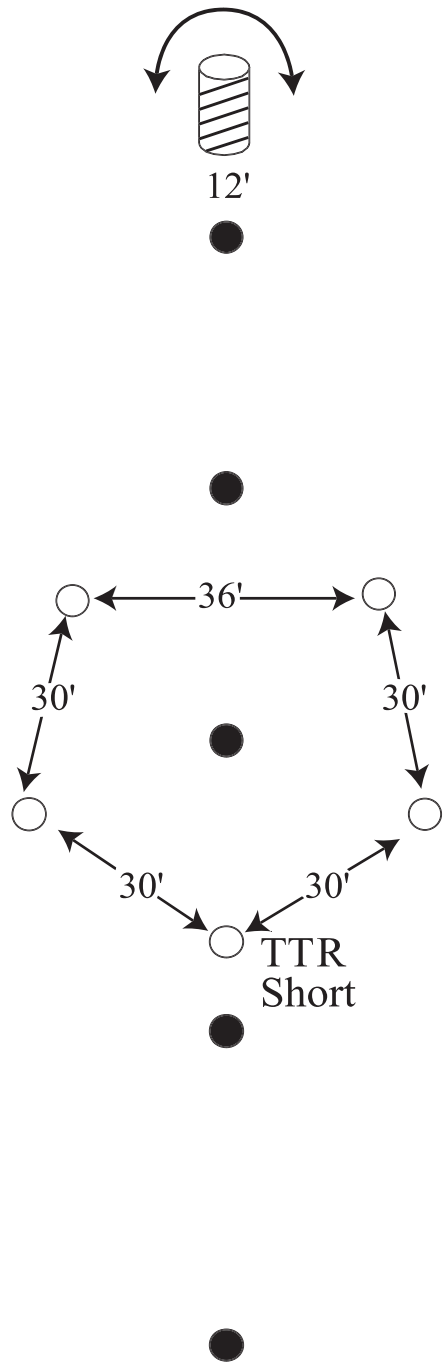

Start/Finish

#50

B. Shoot all the light targets first, before rounding the barrel

Procedurals: 2, 3

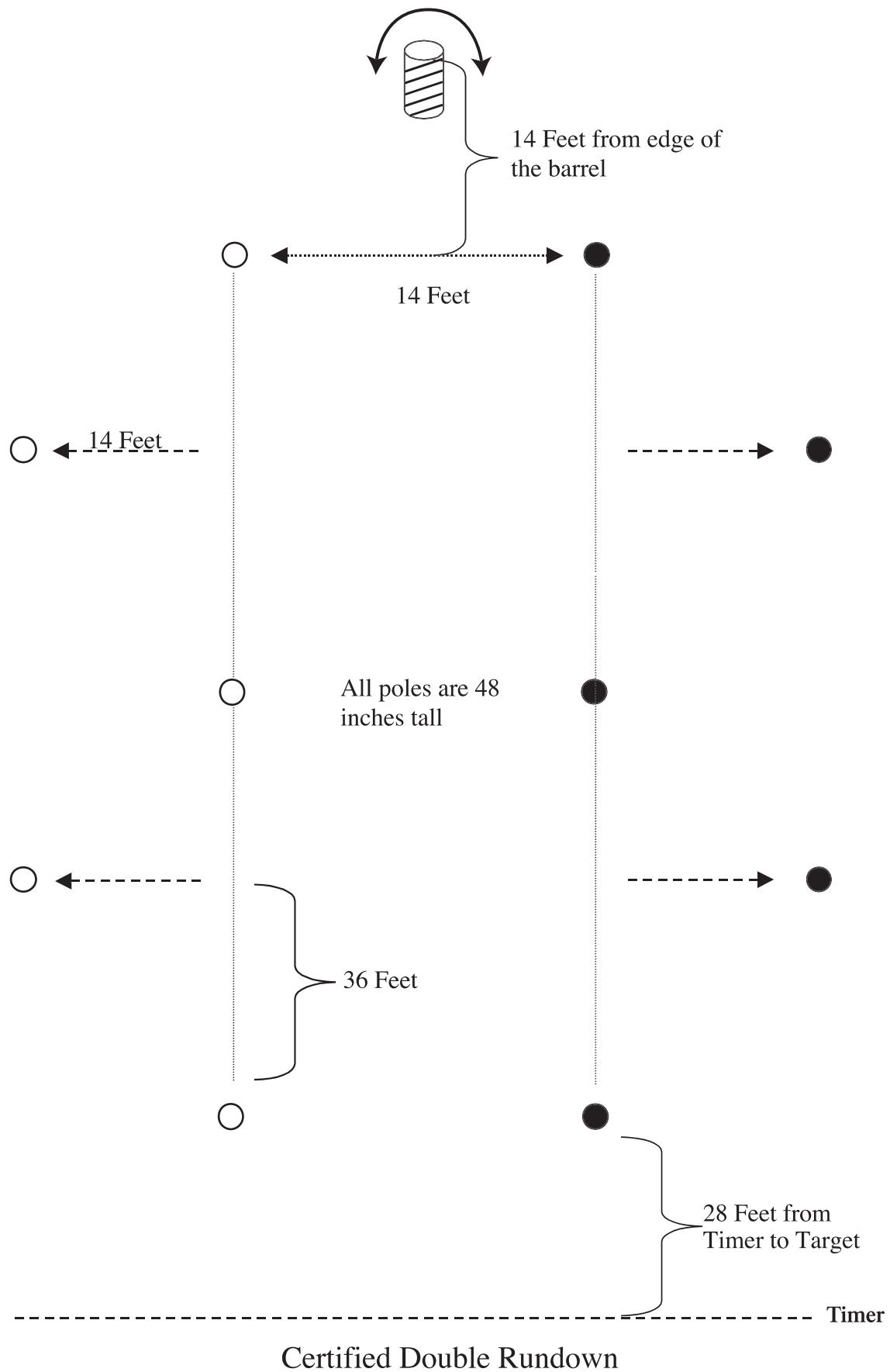

C. Shoot 5 of one color, round the barrel, shoot 5 of the other color
 Procedurals: 2, 3

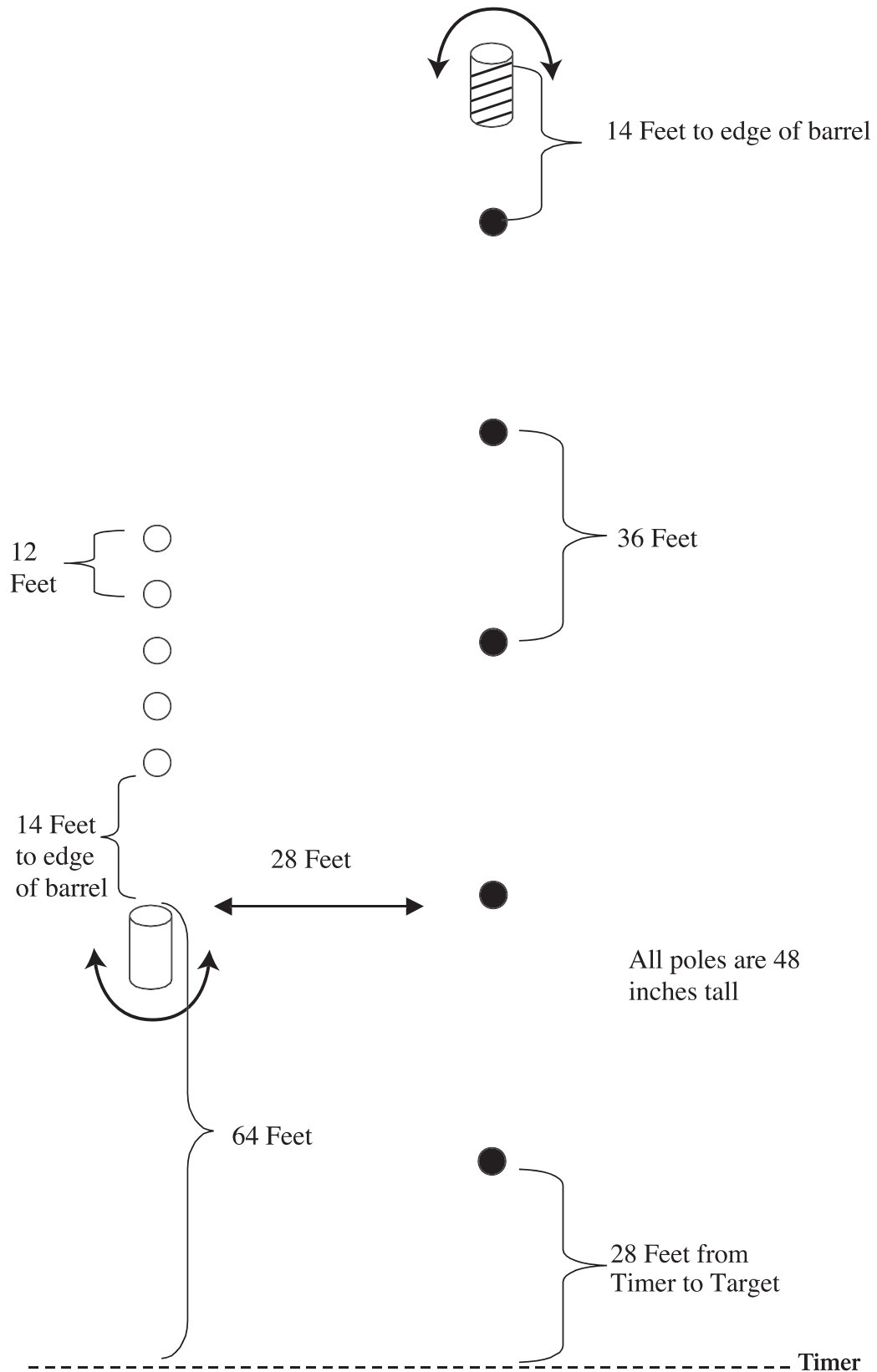

Certified Five in a Row

B. Shoot all the light targets first, before rounding the barrel

Procedurals: 2, 3

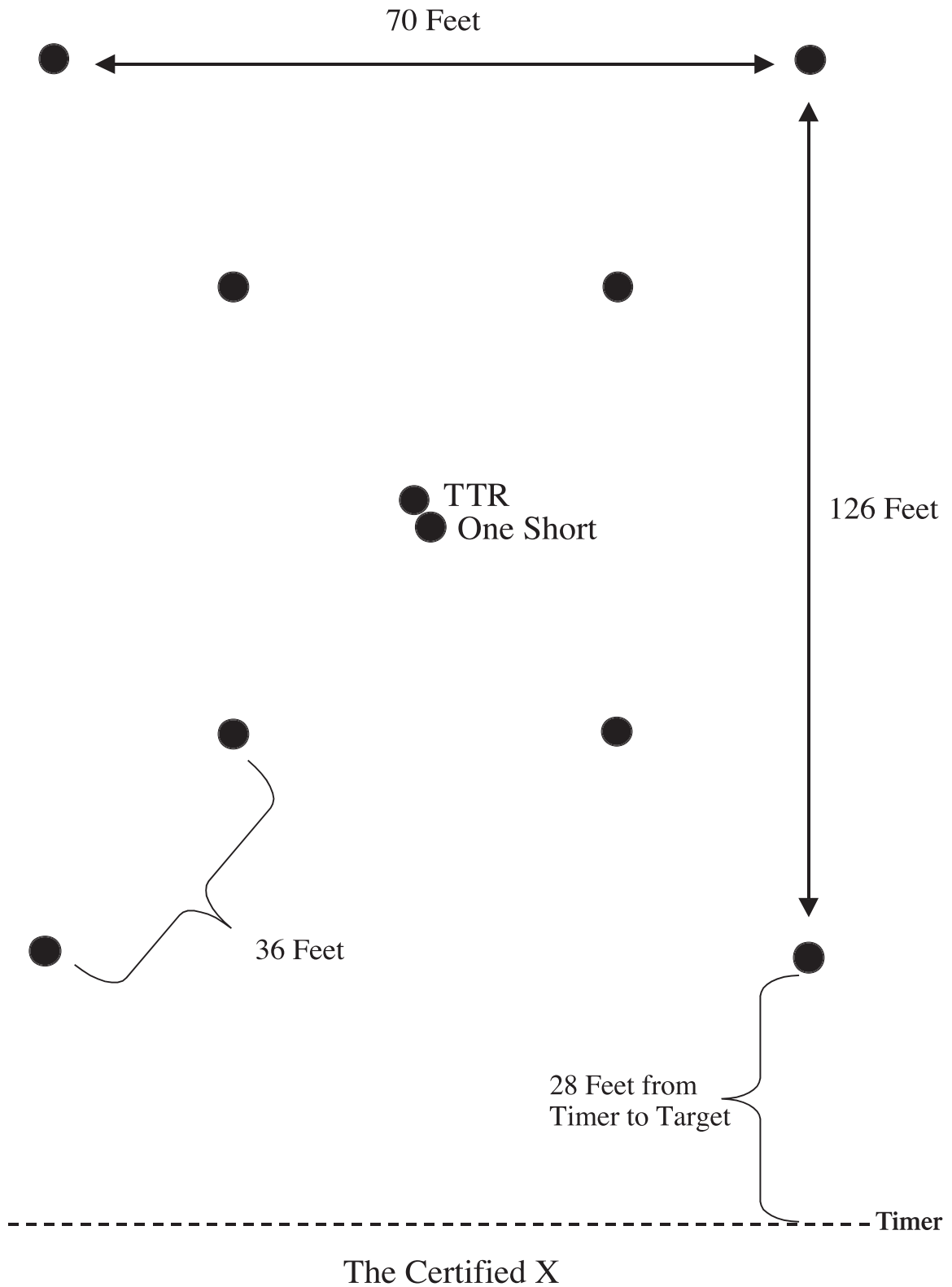

Target shall be the same color.

All poles are 48 inches tall except the center ones, which are 72 inches tall and 24 inches tall.

Contestant may start on either side; the right or left barrel. When starting on the right barrel, there will be one right turn and two left turns. When starting on the left barrel, there will be one left turn and two right turns around barrels.

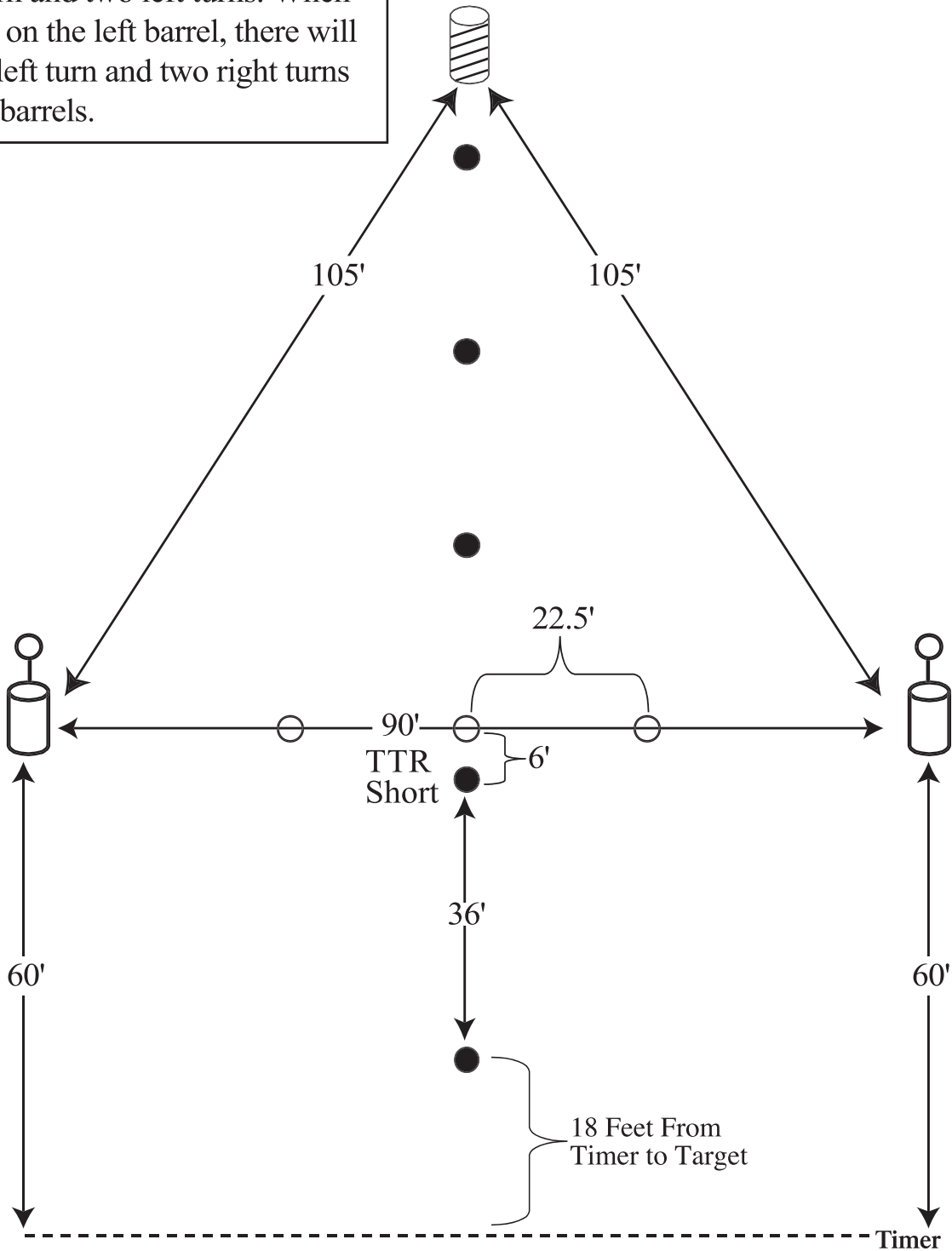

Course 54- Certified Barrel Race

All poles are 48 inches tall except the center ones, which are 72 inches tall (dark targets) and 24 inches tall (light targets).



© CowboyMounted Shooting Association 2007

14227 E. Rock View Road
Scottsdale, AZ 85262
(480) 683-0485
Fax (480) 683-0467
info@cowboymountedshooting.com
www.CowboyMountedShooting.com
